



**HILLSBOROUGH COUNTY  
AVIATION AUTHORITY**

**Design Criteria Manual**

**Revised 09/18/07**

Design Criteria Manual  
Table of Contents

Section 1 Civil Engineering and Site Work

---

- 1.1 Abbreviations
- 1.2 Roadways
- 1.3 Airfield Paving: Runways, Taxiways, and Aprons
- 1.4 Surface Water Management
- 1.5 Site Utilities
- 1.6 Fueling Systems: Aircraft and Automotive - Reserved
- 1.7 AGT Guideways - Reserved
- 1.8 Landscaping and Irrigation
- 1.9 Site Signage and Graphics - Reserved
- 1.10 Access Control - Reserved
- 1.11 Fencing and Gates - Reserved
- 1.12 FAA Systems - Reserved

Section 2 Architecture – Building Engineering

---

- 2.1 Applicable Codes and Reference Standards
- 2.2 Building Objectives - Planning Criteria
- 2.2 Building Objectives - Planning Criteria (Continued)
- 2.2 Building Objectives - Planning Criteria (Continued)

Section 3 Building Sections and Components

---

- 3.1 Division 1 - General Requirements - Reserved
- 3.2 Division 2 - Site Work - Reserved
- 3.3 Division 3 - Concrete
- 3.4 Division 4 - Masonry
- 3.5 Division 5 - Metals
- 3.6 Division 6 - Wood and Plastics
- 3.7 Division 7 - Thermal and Moisture Protection
- 3.8 Division 8 - Doors and Windows
- 3.9 Division 9 - Finishes
- 3.10 Division 10 - Specialties
- 3.11 Division 11 – Equipment - (Reserved)
- 3.12 Division 12 – Furnishings - (Reserved)
- 3.13 Division 13 - Special Construction
- 3.14 Division 14 - Conveying Systems
- 3.15 Division 15 - Mechanical
- 3.15 Division 15 - Mechanical (Continued)
- 3.16 Division 16 – Electrical
- 3.17 Telecommunications Infrastructure Standards
- 3.18 Aviation Authority Labeling Standards

Section 1 – Civil Engineering and Site Work

1.1 Abbreviations for Civil Engineering and Site Work Sections

AUTHORITY	Hillsborough County Aviation Authority
CFR	Code of Federal Regulations
COT	City of Tampa
DOT	Department of Transportation
EPA	Environmental Protection Agency
EPC	Hillsborough County Environmental Protection Commission
ERP	Environmental Resource Permit
FAA	Federal Aviation Administration
FAC	Florida Administrative Code
FAR	Federal Aviation Regulations
FDEP	Florida Department of Environmental Protection
FDOT	Florida Department of Transportation
NGVD	National Geodetic Vertical Datum (1929 or 1983 as applicable)
NOI	Notice of Intent
NPDES	National Pollutant Discharge Elimination system
OSHA	Occupational Safety and Health Administration
PC	City of Plant City
SWFWMD	Southwest Florida Water Management District
SWPPP	Stormwater Pollution Prevention Plan
SPCC	Spill Prevention Control and Countermeasure Plan

1.2 Roadways

1.2.A. Related Sections – Reserved

1.2.B. Scope – Reserved

1.2.C. Applicable Codes and Reference Standards

The design of all Authority roadways intended for automotive vehicular use, and not otherwise subject to any state or federal aviation authority standard, will be in accordance with the design criteria contained in the applicable edition of the State of Florida “Manual of Uniform Minimum Standards for Design, Construction, and Maintenance of Streets and Highways”.

1.2.D. Planning Objectives – Reserved

1.2.E Authority Standards – Reserved

1.3 Airfield Paving: Runways, Taxiways, and Aprons

1.3.A Related Sections – Reserved

1.3.B Scope – Reserved

1.3.C Applicable Codes and Reference Standards

Minimum design standards will be in accordance with the appropriate Advisory Circulars.

All proposed construction standards will be in accordance with Advisory Circular 150/5370-10, Standards for Specifying Construction of Airports.”

The following is a list of Pertinent FAA Advisory Circulars and Federal Aviation Regulations:

Table 1.1 <sup>1</sup> FAA Advisory Circulars and Federal Aviation Regulations	
No.	Title
AC 00-2.12	Advisory Circular Checklist
AC 70/7460-1	Obstruction Marking and Lighting
AC 70/7460-2	Proposed Construction or Alteration of Objects that May Affect the Navigable Airspace
AC 150/5200-33	Hazardous wildlife attractants on/or near airports
AC 150/5230-4	Aircraft Fuel Storage, Handling, and Dispensing on Airports
AC 150/5320-5	Airport Drainage
AC 150/5320-6	Airport Pavement Design and Evaluation
AC 150/5320-14	Airport Landscaping for Noise Control Purposes
AC 150/5300-13	Airport Design
AC 150/5335-2	Airport Aprons
AC 150/5340-1	Standards for Airport Markings
AC 150/5340-18	Standards for Airport Sign Systems
AC 150/5340-30	Design and Installation for Airport Visual Aids
AC 150/5340-1H	Standards for Airport Marking
AC 150/5300-B	Airport Design
AC 150/5345-1	Approved Lighting Equipment
AC 150/5345-44	Specification for Taxiway and Runway Signs

Table 1.1 <sup>1</sup> FAA Advisory Circulars and Federal Aviation Regulations	
No.	Title
AC 150/5345-46	Specification for Runway and Taxiway Light Fixtures
AC-150/5360-9	Planning and Design of Airport Terminal Facilities at Non-Hub Locations
AC 150/5360-13	Planning and Design Guidelines for Airport Terminal Facilities
AC 150/5360-14	Access to Airports by Individuals with Disabilities
AC 150/5370-2E	Operational safety on airports during construction
AC 150/5370-10A	Standards for specifying construction of airports
AC 150/5380-5	Debris Hazards at Civil Airports
AC 150/5380-6	Guidelines and Procedures for Maintenance of Airport Pavements
AC-150/5380-7	Pavement Management System
FAR Part 77	Objects Affecting Navigable Airspace

<sup>1</sup>NOTE: The above listing is not a complete listing of potential applicable FAA Advisory Circulars. The designer should consult FAA.GOV for the current Advisory Circular Checklist that will list the most recent edition and/or change date for a particular circular.

Pavement designs and establishment of subgrade characteristics and properties will be in accordance with the latest edition of the FAA Advisory Circular, AC 150/5320-6, "Airport Pavement Design and Evaluation".

- Erosion and sediment control measures must conform to the specifications contained in the document, Roadway and Traffic Design Standards Erosion Control and Water Quality, published by the State of Florida Department of Transportation.
- Geotechnical testing should conform to applicable sections or ASTM Volume 04.08, Soil and Rock; Building Stones; Geotextiles.
- Geotechnical testing and engineering will be conducted by corporations and experienced individuals licensed to practice this specialty by the State of Florida.

#### 1.3.D Planning and Functional Criteria

Critical Design Aircraft: The Critical Design Aircraft (CDA) will be identified for each project design pertaining to any of the following airfield elements:

- a. Width, Clearances, and Separations of Taxiways and Parking Aprons: The CDA, or its associated Airplane Design Group Number,

---

per AC 150/5300-13, will be recommended by the designer and approved by the Authority.

- b. Pavement Design: The CDA for pavement loading will be based on 727-200 type aircraft and size (length and wing span) based on 747-400 type aircraft or 777-300 except as directed by the Authority.

Geometrics: All airfield geometry will conform to the current Airport Layout Plan (ALP) where applicable, and will accommodate all Group V aircraft unless otherwise directed by the Authority. Detailed geometry not included or referenced on the ALP will conform to the requirements in AC 150/5300-13 and other relevant ACS, except as directed by the Authority.

#### 1.3.D.1 Line-of-Sight

- a. All public-use taxiways will conform to the line-of-sight criteria of AC 150/5300-13. Public use taxiways, under the control of the Air Traffic Control (ATC) tower, will be in full view of the tower cab, full length and width. An ATC Tower Line-of-Sight (Shadow) study will be performed and furnished to the designer for use. The responsibility for preparing this plan will be as directed by the Authority. Aprons and exclusive-use taxiways are not under the control of ATC and, therefore, normally do not require line-of-sight.
- b. Line-of-sight considerations may also be required when facilities are planned and designed near, or in the vicinity of, FAA NAVAIDS. Unless otherwise directed by the Authority, all proponents of construction, except those funded under the Airport Improvement Program (AIP), will complete an FAA Form 7460-1, "Notice of Proposed Construction or Alteration," with appropriate information and exhibits required by the FAA on which the FAA can conduct an Aeronautical Study of the proposal.

#### 1.3.D.2 Gradients and Slopes

All paved and turfed areas on the airfield AOA will conform to the requirements of AC 150/5300-13 and as supplemented by the following criteria:

- a. Side slopes on excavation (cut) and embankment (fill) areas outside of runway and taxiway safety areas will have 4:1 maximum slope.
- b. The standard crowns (transverse slope) on taxiways will be 1.5 %, except where flatter grades are necessary due to

intersection transition in which case, they will be a minimum of 0.5 % for concrete pavements and 0.7 % for asphaltic pavements.

- c. All taxiway shoulders will be graded 5% surface gradient for 10 feet, and then graded between 3% to 5% surface gradient to the edge of the taxiway safety area.
- d. Pavement gradients on aircraft parking aprons will be 0.5 to 1.0%. Where conforming or transitioning to existing facilities, and except for 50 feet from Terminal buildings at the gate/parking positions, they will be 1.0% to conform to NFPA Standard 415 on airport terminal buildings, fueling ramp drainage, and loading walkways.
- e. Gradients and slopes for the following areas will conform to the requirements of AC 150/5300-13 for the respective critical aircraft or mix of aircraft: Obstacle Free Zone, Runway and Taxiway Safety Areas, Clearway, and Stopway.

#### 1.3.D.3 Aprons

Aircraft parking aprons will be based on an Apron Utilization Plan, approved by the Authority. The responsibility for preparing this plan will be as directed by the Authority. Apron utilization criteria, including wingtip clearance, will be approved by the using Tenant and the Authority, and will be within the maneuvering limits of the Aircraft Characteristics Manual of the Critical Design Aircraft.

#### 1.3.D.4 Geotechnical Investigation

Guidelines for a geotechnical investigation are contained in FAA AC 150/5320-6. At a minimum, the following guidelines should be observed in the design investigation:

- a. In apron areas, one STP boring should be performed per 10,000 square feet of area.
- b. In taxiway areas, STP borings should be performed at 200-foot intervals along centerlines.
- c. Borings should be Standard Penetration Tests (SPT), and should extend to at least 10 feet in depth. At approximately 500-foot centers, borings should extend a minimum of 25 feet in depth.

- d. Any potential borrow material sources should be adequately investigated to evaluate acceptability.
- e. Borings and testing locations should carry airport grid coordinate locations, and ground surface NGVD elevations.
- f. Testing locations, procedures, and times of testing should be established well in advance of testing, and must be coordinated with representatives of the Authority. Test locations should be cleared for utilities by the Design Consultant, the Authority, and affected utility companies. All areas disturbed by testing should be restored satisfactorily.
- g. Sufficient field and laboratory testing should be performed to establish classifications and properties for the various strata encountered. This will include determination of Unified Soil Classifications, plasticity/consolidation properties, permeability, in-place density, typical bearing ratio-moduli values, and groundwater conditions.

#### 1.3.D.5 Earthwork

Specific recommendations will be made for the project needs in the areas of clearing and grubbing, undercutting, proof rolling, embankment construction, suitable materials, compaction, stabilization, subgrade preparation, and any special procedures to be used. FAA Advisory Circulars and/or FDOT standards will be reviewed as applicable.

Whenever possible earthwork quantities will be determined by cross section method and cross sections will be included in the plane. For unit cost projects, the earthwork will be separated into the following pay items as appropriate:

- unclassified excavation
- unsuitable excavation
- embankment
- off site borrow

#### 1.3.D.6 Pavement Design

The pavement design process should be in accordance with FAA standards, and will explore the various feasible alternatives. The determination of recommended pavement sections should consider all factors including initial cost, constructability, long-term maintenance, past experiences at Tampa International Airport, and adaptability to future changes. Pavement design for all airfield pavements, except service roads, will be as directed by the Authority, and will be based on FAA methodology and requirements in AC 150/5320-6. Service roads will conform to FDOT standards.

#### 1.3.D.7 Pavement Type

All air carrier airfield pavements will be rigid Portland Cement Concrete (PCC) pavement, General Aviation Taxiways or Ramps and blast protective pavement (shoulders) will be asphaltic concrete pavement. Blast protective pavement type will be recommended by the designer, based on an occasional pass by the critical maintenance or Crash/Fire/Rescue (CFR) equipment. General Aviation Pavement will be designed for the most demanding aircraft and approved by the Authority.

#### 1.3.D.8 Subgrade, Soils, and Pavement Testing and Investigation Program

Designer will prepare a recommended design testing program for review and approval, and in conformance with geotechnical parameters found elsewhere in this manual. All airfield and laboratory testing will be coordinated with the Authority.

#### 1.3.D.9 Underdrains

An underdrain/edge drain system should be reviewed for necessity on all pavement sections. If underdrains are not recommended, the designer will present the basis on which they are not recommended and submit to Authority for approval. System layout, elements, and design will be designed based on soils investigation results, pavement function, and other relevant factors and parameters.

#### 1.3.D.10 Concrete Demolition

All existing airfield concrete pavement to be removed will be crushed to meet the FAA P-209 grading specification and re-used as approved by the Authority. This material will be incorporated into the following items and approved by the Authority as applicable:

- a. Aggregate source for econcrete subbase (FAA P-306).

- b. Aggregate source for 6" crushed aggregate base course to be constructed under econocrete. (FAA P-209)
- c. Aggregate source for shoulder base course. (FAA P-209)

\*Existing econocrete subbase materials will not be incorporated into the crushing operations when creating the FAA P-209 crushed aggregate material.

#### 1.3.D.11 Subbase and Base Course

All full-strength airfield pavements will include a six-inch Econocrete subbase (FAA P-306) as a minimum. A 6" crushed aggregate base course (FAA P-209) will also be included if sufficient crushed concrete materials are available.

#### 1.3.D.12 Portland Cement Concrete (PCC) Pavement

PCC will be designed based on 650 PSI flexural strength at twenty-eight (28) calendar days. Mix design proportions and criteria will meet FAA P-501 (AC 150/5370-10). Longitudinal and transverse construction / contraction joints will be doweled. Keyways are not allowed. Surface texture may be burlap drag or broom finish. Joints for aprons will be sealed with a cold silicone dow corning 888 or 890-SL as applicable. Joints for runways and taxiways will be sealed with CRAFCO Roadsaver 222. Prefomed joint sealers will be used on all sawed contraction joints.

#### 1.3.D.13 Asphalt Pavement

Asphalt pavement will be used on shoulders and General Aviation Ramps and Taxiways/Taxilanes. Mix design proportions and criteria will be FAA P-401 (AC 150/5370-10). All concrete-to-asphalt conform joints will be sawed and sealed to retard moisture intrusion and vegetation growth.

#### 1.3.D.14 Pavement Marking

Pavement marking of aprons, taxiways, taxilanes, and paved shoulders will conform to AC 150/5340-1, and approved by the Authority. Taxiway centerline markings and apron taxilane marking will be yellow and a minimum of 12 inches wide. All taxiway/taxilane centerline markings (on concrete) will have a 6" black outline applied. Glass beads will be applied as directed in the Advisory Circular. All runway markings will be white with a 6" black outline as required by the Advisory Circular. Lead-in lines will be yellow, fire lanes will be red, and service roads will be white. P-620 paint will be latex TT-P-

1952 acrylic and will be applied as a double application. Reflective beads of the type indicated on the AC will be applied with the second coat of paint at the locations indicated by the AC and/or directed by the Authority.

#### 1.4 Surface Water Management

##### 1.4.A Related Sections – Reserved

##### 1.4.B Scope – Reserved

##### 1.4.C Applicable Codes and Reference Standards

- The drainage requirements of the Authority and the FAA will be met.
- The drainage connection permitting requirements of the FDOT, Chapter 14-86, F.A.C., will be met, if applicable.
- All proposed drainage structures and construction methods will be in accordance with FDOT Roadway and Traffic Design Standards (Latest Version - English Units), and Standard Specifications for Road and Bridge Construction most recent version (English Units). Special design considerations will be applied when drainage structures are located within airfield pavement or safety areas of the airfield.
- All dredge and fill activities in wetlands and waters of Florida may require permits. All permits will be obtained for these activities from FDEP, SWFWMD, HCEPC, and the USCOE (United States Army Corps of Engineers).
- The surface water management system design methods will be in accordance with approved SWFWMD, FDOT, City of Tampa, and FAA design methodologies, which is/are applicable, and most restrictive.
- All building, parking, and roadway areas will meet SWFWMD, City of Tampa, and other applicable federal, state, or local criteria regarding finish floor or low edge of pavement elevations.

##### 1.4.D Guidelines for Surface Water Management Design

- All features of any storm water management system proposed for the Authority projects are to be conceptually visualized and depicted on preliminary drawings, coordinated with any existing authenticated “Master Drainage Plan” and approved by the Authority. These documents are to be presented in preliminary meetings with applicable regulatory agencies for comments and conceptual approval prior to final design.

- Coordination with regulatory agencies, such as SWFWMD, City of Tampa, FDEP, EPC and so forth, will be conducted prior to the design of the surface water management system to determine the exact regulatory permitting requirements.
- Representatives of SWFWMD, FDEP, and HCEPC should be contacted and arrangements made for a field review. Existing permitting treatment systems should be identified and modifications/mitigation plans coordinated with regulatory agencies.
- All permit application documents will be submitted to the Authority for review and comment prior to their submission to any agency.
- The surface water management system must be designed to alleviate existing flooding problems to permanent structures within the project area. Any relocated drainage structures or storm water systems must be able to convey the flows of their initial design. There should be no decrease in peak flow capacity to existing storm water systems or increases in hydraulic gradients which would cause increased flooding on or off airport property as a result of the proposed surface water management system.
- The modifications to the surface water management system will not degrade the existing water quality of the Spruce Street Canal Basin. The co-mingling of treated and untreated storm water runoff should be prevented.
- Off-site areas upstream and downstream will not be adversely affected by the time, stage, volume, or point or manner of discharge from the surface water management system.
- Existing pump/irrigation systems will be considered in the surface water management system design. Existing storm water control structures (i.e., weirs, orifices, and so forth) will be considered in the surface water management system design.
- The alignments of proposed conduits do not necessarily have to meet the alignment of existing ditches. The conduit lengths and sizes should be kept to the minimum requirement necessary to meet the design criteria.
- The velocities of flow over grassed areas should be kept to a low enough level to prevent erosion.
- Extended periods of ponding in depressed areas should be prevented to decrease the potential of “bird strikes.”
- Clearances of ground water levels to the pavement bases should be sufficient to prevent adverse impacts to the pavements and pavement bases.

- The net differences in impervious areas (i.e., pavement added, versus pavement removed), will be considered in the surface water management system design and permitting. A zero net difference will be achieved if possible.
- If storm water pond facilities are necessary for quantity and for quality treatment, FAA AC 150/5200-33 “Hazardous Wildlife Attractants on or near Airports” will be reviewed. Ponds will be “dry detention” rather than wet detention. Side slopes will be 4:1 (minimum) with a ten foot (minimum) maintenance berm. Whenever possible water quality standards will be met by utilizing “Detention with effluent filtration systems (manmade under drains).” For airfield projects, quality standards will be met by utilizing Best Management Practices (BMPs) design such as vegetative control measures wherever possible. Water quantity standards may or may not be required depending on the drainage basin in which the project is located.
- All existing contributing drainage areas including roadways, parking areas, off-site areas, and so forth, will be included in the surface water management system design.

#### 1.4.E Storm Sewers

- All storm drain culverts will be reinforced concrete Class III or IV (depending on loading conditions) and will conform to FDOT’s “Standard Specifications for Road and Bridge Construction”, latest version.
- All Drainage Structures will conform to the FDOT’s “Roadway and Traffic Design Standards”, latest version. Special design considerations will be applied when drainage structures are located within airfield pavements or safety areas of the airfield.
- The hydraulic gradient elevation in manholes and inlets will be a minimum of 1.0 foot below the throat of inlet or top of manhole unless minor energy losses are considered in the hydraulic calculations. The minimum physical slope will produce a flow velocity of 2.5 fps (min.) when flowing full.
- The maximum length of pipe between access entry structures will be 300 feet for pipes less than 18 inches, 400 feet for pipes 24-36 inches, and 500 feet for pipes greater than 36 inches.
- For all pipes 36” in diameter and greater to be installed on airfield projects, the contractor must provide the pipe supplier certified D-load test results for any lot of pipe delivered to the site.
- Pipe bedding will consist of a bed of granular material having a thickness of at least six inches (6”) below the bottom of the pipe and extending up around the pipe for a depth of not less than 30 % of its vertical outside diameter. Filter

fabric will be placed over the granular material and each pipe joint will be wrapped with a minimum one foot (1') overlap.

- All pipes are to be kept clear of debris at all times during construction. After the completions of all earthwork and the placement of all sod and/or seeding and mulching and before final acceptance, all pipes will be cleaned of silt, debris, etc. to the satisfaction of the Engineer. This may require the de-watering of the pipes. Care must be taken during this operation so as not to damage the pipes or the surrounding areas.

#### 1.4.F NPDES Generic Permit for Construction Activities

A NOI for NPDES Generic Permit must be filed with FDEP for construction sites where more than 1 acre of land is disturbed. FDEP Form 62-621.300 (4) (b) must be submitted and a copy of a SWPPP must be kept onsite. If an Environmental Resource Permit (ERP) was issued by SWFWMD, the Erosion and Sediment Control Plan prepared as part of the permit requirements can be used in lieu of a SWPPP, provided that all requested information is included in the Erosion and Sediment Control Plan. At the completion of the work Notice of Termination, on Department form 62-621.300(6) must be submitted.

### 1.5 Site Utilities

#### 1.5.A Related Sections

1.5.A.1.1.1 Section 1.4 Surface Water Management

1.5.A.1.1.1.2 Section 2.2.A.6 Typical Facility Plumbing

1.5.A.1.1.1.3 Section 3.15

1.5.A.1.1.1.4 Section 3.15

1.5.A.1.1.1.5 Section 3.15

#### 1.5.B Scope – Reserved

#### 1.5.C Storm Sewers

Excepting as may be specifically approved by the Authority, all storm drain pipe is to be reinforced concrete, of a minimum diameter of 15 inches, and conform to the FDOT “Standard Specifications for Road and Bridge Construction”, Concrete Pipe Section 941-1 and 941-2. Other pipe types that may be considered are polyvinyl chloride and corrugated polyethylene as appropriate for the project and approved by the Authority.

All Drainage Structures will conform to the FDOT's "Roadway and Traffic Design Standards", Index Nos. 199-295.

The minimum physical slope will produce a flow velocity in Concrete pipe of 2.5 fps min. and 12.0 fps max. when flowing full. The minimum physical slope will produce a flow velocity in Corrugated Metal Pipe (when allowed) of 2.5 fps min., and 10.0 fps max. when flowing full.

The hydraulic gradient elevation in manholes and inlets will be a minimum of 1.0 foot below the throat of inlet or top of manhole unless minor energy losses are considered in the hydraulic calculations. The minimum physical slope will produce a flow velocity of 2.5 fps (min.) when flowing full.

The maximum length of pipe between access entry structures will be 300 feet for pipes less than 18 inches, 400 feet for pipes 24-36 inches, and 500 feet for pipes greater than 36 inches.

#### 1.5.D Sanitary Sewers and Force Mains

Gravity sanitary sewers will be Polyvinyl Chloride for normal use and Ductile Iron for occasions requiring special strength or protection.

Polyvinyl Chloride pipe and fittings will conform to ASTM Specifications D-304 (SDR 35). The bell end of joints and fitting will have a rubber sealing ring to provide a tight, flexible seal in conformance with ASTM D-3212-76. The maximum laying length will be 12.5 feet.

Ductile Iron pipe and fittings for gravity sewers will conform to the specification for Ductile Water pipe (see Section 1.4.E), excepting that Ductile Iron pipe conveying sanitary sewer will have an interior "polylining" per manufacturer's recommendations.

Sanitary sewer force mains will be either Polyvinyl Chloride or Ductile Iron and will conform to the Polyvinyl Chloride and Ductile Iron specifications for water mains (see Section 1.5.E following), excepting that Ductile Iron pipe will be provided with an interior "polylining" in accordance with manufacturer's recommendation.

#### 1.5.E Water Mains and Appurtenances

Ductile Iron pipe and fittings will be in accordance with ANSI / AWWA C 151 / A21.51-81. Pipe will have an asphalt coated exterior and a cement lined interior in accordance with ANSI / AWWA C104 / A21.4-80.

Pipes larger than 8 inches will be Ductile Iron.

Polyvinyl Chloride pipe (up to and including 8 inch size) will be in accordance with ANSI / AWWA C900-81 and with ASTM-D2241 and D-1784.

PVC pipe must be compatible with Cast and Ductile Iron pipe without the need for special adapters.

The bell of PVC pipe will consist of an integral wall section with an elastomeric ring which meets the requirements of ASTM D-1869.

Gate valve discs will be suitable for operation in any position with respect to the vertical. Valves for interior piping or exposed above grade will be handwheel operated.

Valves three inches and larger buried below grade will be equipped with a two inch square operating nut, valve box, and cover. The direction of opening for all valves will be to the left (counter-clockwise). Unless otherwise specified, valves for pressure service will be rated at not less than 150 psi, cold water, and nonshock.

Fire hydrants will be in accordance with AWWA Specification C-502 with breakable, dry-barrel, in two sections with the breaking flange located approximately 2 inches above the ground line. The main valve opening will not be less than 5 ¼ inches, and the hydrant nozzles will consist of two 2 ½ inch hose nozzles and one 4 ½ inch pump nozzle. The hydrant will be equal to a Mueller Centurion, Catalog Number A-423.

Backflow preventers will be above ground and will be of the double check valve assembly type or the reduced pressure type depending on the degree of hazard associated with the event to be prevented.

#### 1.5.F Sanitary Sewer – Pretreatment Devices and Other Appurtenances

##### 1.5.F.1 Applicable Standards and Regulations

Wastewater Discharges are regulated by the City of Tampa for the majority of the areas located within the boundaries of Tampa International Airport (TPA) and for Peter O. Knight Airport (POK) and Vandenberg Airport (VAN). Wastewater discharges from Plant City Airport (PCA) are regulated by Hillsborough County and the City of Plant City.

##### City Section 26 (Utilities) Article III Sanitary Sewers

Sec. 26-120. Excluded wastes prohibits...“any person to discharge or deposit any waste, waste material, gases, toxic materials or wastewater which contains any pollutants of a type, nature, temperature or concentration not found in normal domestic wastewater to the treatment works.”

In addition “The department’s Technical Manual of Standards for Industrial and Special Users sets forth the limitations and types of excluded wastes

which may be discharged following pretreatment.” (Ord. No. 89-253, § 2(58-126), 9-28-89)

All operations that generate wastewater other than sanitary wastewater will be equipped with pretreatment devices or appurtenances that will pretreat the generated wastewater to effluent levels compliant with the City of Tampa Code referenced above. The City of Tampa (or the regulating entity) will be contacted to confirm that the discharge is allowed.

#### 1.5.F.2 Wash Racks

All wash racks built at Tampa International Airport for aircraft washing must meet the requirements of the Aircraft Washing Operating Directive. All other wash racks must meet the following requirements. Regardless of the type of pretreatment provided, all wash rack outlets will be connected to the sanitary sewer system, which is separate from the storm water drainage (sewer) system. The system can be designed with a bypass that allows the discharge of wastewater to the sanitary system, while diverting storm water runoff to the storm water drainage system.

An oil/waster separator will be installed as a pretreatment system before the wastewater is discharged into the sanitary sewer system. A sand trap is also recommended.

#### 1.5.F.3 Floor Drains

All building floor drains will be connected to the sanitary sewer system. Depending on the types of activities conducted inside a building, the following appurtenances may be required in order to comply with the City of Tampa wastewater effluent disposal requirements:

**Oil/Water Separator** – They are required for all vehicles and equipment washing activities. A sand trap may also be required.

**Acid Tank** – If there is a potential for acidic wastewater or other similar liquids to be generated inside a building during equipment washing, floor washing, or other operations, an acid tank will be installed.

**Grease Traps** – Grease traps must be installed for all restaurant generated grease waste as required by local codes.

Dumpsters, waste compactors, and other waste handling equipment will be installed such than any wastewater or leachate generated through contact of water or storm water with the waste is discharged to the sanitary sewer system. Pretreatment may be required depending on the characteristics of the leachate.

#### 1.5.F.4 Utility Permits

Coordination with regulatory agencies, such as City of Tampa Water Department (water service commitment), City of Tampa Department of Sanitary Server (sanitary sewer service commitment), Hillsborough County Health Department (water distribution system approval), EPC, (sanitary sewer collection system approval), Hillsborough County Water Department (water service commitment), Hillsborough County Sanitary Sewer Department (sanitary sewer service commitment) will be conducted during the design phase to determine the exact regulatory permitting requirements.

All permit application documents will be submitted to the Authority for review and approval prior to their submission to any agency.

### 1.6 Fueling Systems: Aircraft and Automotive – Reserved

#### 1.6.A Related Sections – Reserved

#### 1.6.B Scope – Reserved

#### 1.6.C Applicable Codes and Reference Standards

Storage tanks which are regulated by federal, state and local agencies must be registered with the FDEP. As defined by FDEP, a “Storage Tank System” includes all tanks, integral piping, dispenser, and release detection equipment. See Chapter 62-761 Florida Administrative Code (FAC) for complete definitions and rules pertaining to underground storage tanks (UST’s) and aboveground storage tanks (AST’s). Regulated systems generally consist of:

- 1.6.C.1 Underground storage tanks (UST) with capacities of greater than 110 gallons;
- 1.6.C.2 Stationary aboveground storage tanks (AST) with capacities of greater than 550 Gallons that store pollutants or hazardous substances.

In addition, if a facility has a single AST with a capacity greater than 1,320 gallons, the facility must also comply with the federal Oil Pollution Prevention regulation (40 CFR 112). Once a container exceeds the 1,320-gallon threshold, all containers with a capacity of 55 gallons or more are regulated under this rule. In compliance with this regulation, A Spill Pollution Control and Countermeasure (SPCC) plan must be prepared and implemented.

The applicable rules, registration forms, and notification forms referenced above can be retrieved from the following websites:

[http://www.dep.state.fl.us/waste/quick\\_topics/rules/documents/62-761.pdf](http://www.dep.state.fl.us/waste/quick_topics/rules/documents/62-761.pdf)

[http://www.dep.state.fl.us/waste/quick\\_topics/forms/pages/62-761.htm](http://www.dep.state.fl.us/waste/quick_topics/forms/pages/62-761.htm)

<http://www.epchc.org/waste.htm>

[http://www.access.gpo.gov/nara/cfr/cfrhtml\\_00/Title\\_40/40cfr112\\_00.html](http://www.access.gpo.gov/nara/cfr/cfrhtml_00/Title_40/40cfr112_00.html)

All tanks, piping, and related equipment must be on the most recent edition of the FDEP Approved Equipment List, which can be found at:

[http://www.dep.state.fl.us/waste/quick\\_topics/publications/pss/tanks/](http://www.dep.state.fl.us/waste/quick_topics/publications/pss/tanks/).

All site sample collection, site assessment activities, and all laboratory analyses will be conducted in compliance with the most current FDEP Standard Operating Procedures:

The “Soil Assessment and Sampling Methods for Florida Bureau of Petroleum Storage System Sites” can be found at:

<http://www.dep.state.fl.us/waste/quicktopics/publications/pss/pcp/apsoil-MEMO.pdf>.

The collection of DEP SOPs found in DEP-OP-001/01 (Field Procedures) and DEP-SOP-002/001 (Laboratory Procedures) can be found at:

<http://www.dep.state.fl.us/labs/qa/2002sops.htm>

#### 1.6.D Aircraft Hydrant Fueling System

New Installation: At Tampa International Airport, jet fuel is delivered via the hydrant fueling system from the Bulk Fuel Farm to all the airside.

- All new piping for the hydrant fuel will be double walled piping in compliance with current FDEP regulations 62-761 (FAC)
- All hydrant pits will be made on the most recent edition of the FDEP Approved Equipment List. If a proposed hydrant pit is not on the list, the engineer or contractor will contact the FDEP and notify Authority staff as early as possible.

- Interstitial space will be filled with nitrogen with a pressure of 10 psi (pound per square inch) or more, or will have a vacuum with a pressure of -10 psi or less.
- Pressure gauges will be installed to accurately monitor the interstitial space. Valves will be installed to allow visual monitoring for leaks and will be designed such that the proper pressure can be restored after visual testing.
- A Release Detection Response Level (RDRL) will be prepared by the Engineer using the FDEP RDRL Guidance document. The RDRL will be submitted for review by Authority and EPC staff before the final inspection by EPC staff.
- Removal and Abandonment of Existing Hydrant Piping
- Before the removal and abandonment of any existing hydrant fuel piping or components, the operator of the system (currently ASIG) will be contacted by the Authority in order to have the fuel removed and valves secured as needed. Once the necessary work has been completed, the Authority will notify the Engineer/Contractor.
- Residual fuel will likely remain on the line and must be appropriately handled by the contractor in charge of the removal or abandonment of the line.
- For piping that will be removed, “pigging” is allowed, provided that the residual fuel and the waste generated are prevented from reaching the surrounding soil and is disposed of in accordance with applicable regulations.
- Piping that will permanently be left in place will be grouted once the residual fuel has been removed. In some cases, the Authority will allow some piping be left in place without grouting. However, all residual fuel must be removed and the line must be certified gas free or filled with nitrogen to prevent corrosion.

#### 1.6.E Automotive, Emergency Generator, and Other Tank Fueling Systems

The Authority recommends that fuel tanks used for automotive and emergency generators be stored in aboveground storage tanks instead of underground storage tanks. Emergency Generator tank will be less than 550 gallons to the extent possible. As indicated above, such tanks are exempt from FDEP regulations.

- All regulated tanks will be double walled tanks or have secondary containment in compliance with Rule 62-761 FAC.

- Tanks and fuel dispensing equipment will be located as far as possible from storm water inlets.
- For all systems that fall under the SPCC regulations, the operator of the system must have an SPCC plan prepared in compliance with the Federal regulations and submitted to EPC and the Authority before the system is put in service.
- A Release Detection Response Level will be prepared by the Engineer and submitted for review by Authority and EPC staff before the final inspection by EPC staff. The FDEP “Release Detection Response Level Guidance” document will be used in the preparation of the RDRL; it can be found at: <http://www.dep.state.fl.us/waste/quicktopics/publications/pss/tanks/rdrl.pdf>

#### 1.6.F Notification and Registration Protocol

- Notify and coordinate all activities with the Authority Maintenance Engineering Department.
- Determine whether the storage tank system is a regulated system. If the system is not regulated, no tank registration is required. However, copies of the design plans will be sent to the EPC for their records and submitted to Authority staff for review.
- Submit storage tank system designs and a copy of the completed Storage Tank Registration Form to the EPC for review. If a tank system is being removed, an application for Closure of Pollutant Storage Tank System Form will be submitted to EPC. EPC will review the plans and approve them or return the submittal with comments for revisions. After revisions have been made, re-submit the documents to EPC for approval. A copy of the approved plans will be submitted to the Authority.
- As applicable, obtain the appropriate construction permits from the city or county and submit copies to the Authority.
- Provide the Authority and EPC with advance written or verbal notices as follows:
  - Ten calendar days advance notice for tank installation, replacements, or upgrades.
  - 30 calendar days advance notice for tank closures.
  - Send the completed Storage Tank Registration Form to FDEP in Tallahassee with copies to EPC.

- Provide the Authority and EPC a 48-hour advance notification prior to commencement of on-site work for all tank removals, installations, replacements or upgrades. If work is to be completed in stages, this 48-hour notice is required prior to each stage of work.
- After completing steps above and approval by the Authority, work may begin. (Note: if an UST system is being installed or removed, an Underground Storage Tank Installation and Removal Form for Certified Contractors must be completed and submitted to EPC and the Authority after work is complete on the tank system.
- Copies of all applicable forms, plans, reports, and record drawings will be submitted to the Authority's Planning and Development Engineering Department.

#### 1.6.G Design and Installation Requirements – Reserved

#### 1.6.H Underground Storage Tank Removal/Abandonment Pre-Tank Removal Requirements

- Notification of tank closure (removal) to appropriate agencies as per the protocol, including the Fire Department, or local Fire Department, as applicable.
- Only a State Certified Pollutant Storage Systems Contractor will perform tank removals. A copy of the Contractor's or sub-contractor's certification must be submitted prior to commencement of the Work.
- A Work Plan will be prepared and submitted prior to commencement of work.
- A Health and Safety Plan will be prepared and submitted prior to commencement of work.
- When groundwater monitor wells are present, samples must be obtained prior to tank removal.
- Tank removals will be performed in accordance with FDEP's Storage Tank System Closure Assessment Requirement (latest edition). A copy of this guidance document can be obtained for the FDEP website at: <http://www.dep.state.fl.us/waste/quicktopics/publications/pss/tanks/reference/6closure.pdf>

#### 1.6.I Tank and Soil Removal Operations

- All interior liquid from the tank and integral piping must be properly removed and disposed of prior to tank removal.

- During excavation, soil samples will be continuously screened for organic vapors following the FDEP “headspace” method using an organic vapor analyzer (OVA) equipped with a flame ionization detector (FID) or equivalent.
- All contaminated soils excavated during tank removal will be placed on, and covered with, plastic sheeting and secured.
- Soil samples will be collected and analyzed for the FDEP “Pre- Burn” constituents prior to removal of contaminated soil from site for disposal.
- All contaminated soil disposal manifests will be supplied to the Authority as part of the Closure Assessment Report.

#### 1.6.J Tank Disposal Operations

- Tank will be purged for all volatile and explosive vapors prior to entry and/or removal of interior sludge.
- Tank will be rendered unsuitable for future use as a storage tank by drilling or cutting holes in the tank before removal of it from the site.
- Tank disposal manifests will be included as part of the Closure Assessment Report.

#### 1.6.K Free Product Removal and Groundwater Testing

- Should any free product be encountered in tank system excavation, it should be removed by appropriate methods, (i.e., absorbent mats or vacuum suction).
- Should groundwater be encountered less than 20 feet below land surface, samples will be obtained from each monitor well before tank removal. If there are no monitor wells present, a temporary well point should be installed in the area of highest OVA reading or in the area of the tank fill port before excavation is backfilled.
- If groundwater is more than 20 feet below grade, coordinate with appropriate governmental agency to determine if sample is required.

#### 1.6.L Storage Tank Forms

The following forms, where applicable, should be included in the Closure Assessment Report and also submitted to the appropriate agencies:

- Application for Closure of Pollutant Storage Tank Systems which can be found at:  
<http://www.epchc.org/PDF%20Forms/Closure%20Application%20letterhead.pdf>
- Underground Storage Tank Installation and Removal Form for Certified Contractors, which can be found at: <http://www.dep.state.fl.us/waste/quicktopics/forms/documents/62-761/7615.pdf>;
- The following form must also be submitted to EPC:  
<http://www.epchc.org/PDF%20Forms/Install%20EPC%20letterhead%20New.pdf>
- Discharge Reporting Form and Incident Reporting Form which can be found at:  
<http://www.dep.state.fl.us/waste/quicktopics/forms/documents/62-761/7611.pdf>; and: <http://www.dep.state.fl.us/waste/quicktopics/forms/documents/62-761/7616.pdf>;
- Storage Tank Registration Form and instruction which can be found at:  
<http://www.dep.state.fl.us/waste/quicktopics/forms/documents/62-761/7612.pdf>; and: <http://www.dep.state.fl.us/waste/quicktopics/forms/documents/62-761/codes.pdf>;
- Limited Closure Summary Report Form which can be found at:  
<http://www.dep.state.fl.us/waste/quicktopics/forms/documents/62-761/7618.pdf>; and/or Petroleum or Petroleum Product Contamination Report Form.

#### 1.6.M Closure Assessment

- For sites with documented soil or groundwater contamination that has already been reported to the regulatory agencies, a closure assessment is not required prior to the removal or abandonment of USTs, ASTs, and appurtenances. However, a Limited Closure Summary Report Form must be filled out and submitted to the EPC.
- For all other site, a “full” Closure Assessment is required and a Closure Assessment Report must be prepared as described below.
- Closure Assessment Report will include all items from the attached checklist.

#### 1.6.N Post-Removal Activities

- Return the site to original condition or as otherwise specified.
- Remove all debris.

- Address contaminated soils and/or groundwater in accordance with pertinent regulatory requirements.
- Provide the Authority with a copy of the complete Closure Assessment Report including all pertinent drawings and specifications.

1.7 AGT Guideways - Reserved

1.8 Landscaping and Irrigation

1.8.A Related Sections – Reserved

1.8.B Scope – Reserved

1.8.C Applicable Codes and Reference Standards

Landscape treatment will be provided in accordance with the City of Tampa Municipal Code Chapter 13 (Latest Version), “Landscaping, Tree Removal, and Site Clearing”, and any other applicable City of Tampa Rules and Regulations.

Plans, specifications, and inspection for landscaping will be accomplished by a professional landscape architect registered in the State of Florida.

All plant materials will be in accordance with “Grades and Standards for Nursery Plants, Parts I and II”, latest edition, as published by the Florida Department of Agriculture and Consumer Services. All plants not otherwise specified as being “Specimen,” will be Florida Grade Number One or better, as determined by the Florida Division of Plant Industry. “Specimen” refers to an exceptionally dense, symmetrical plant, so trained or favored in its development that its appearance is unquestionable and outstandingly superior in form, number of branches, compactness, and symmetry.

1.8.D Planning Objectives

Primary design objectives for the proposed project area will focus on the following areas of concern:

- Maintaining and Reinforcing the Central Theme of Existing Planting Areas: By using certain varieties of landscape materials that currently exist within the terminal complex, a unity in design will result to enhance and reinforce the existing overall design concept.
- Protecting Existing Plan Materials: Existing trees and shrubs will be protected.
- Relocating Existing Trees: Existing trees that must be removed due to proposed construction will be relocated to a suitable location within the

terminal complex whenever possible, at the direction of Authority. Tree relocation will be accomplished by a qualified and licensed mechanical tree mover and will be coordinated with Authority.

- Visual Screening and Aesthetic Effects: Visual screening will be used where service-oriented and mechanical facilities, if any, are visually adjacent to public areas. Screening materials will consist of large trees and shrubs, berm/hedge combinations, or walls. Service facility walls should be softened with ground cover. The transition from parking area to public right-of-way can be made more visually pleasing with partial or intermittent screens of plant materials, which also function as a defining edge for the parking area.
- Heat and Glare Reduction: Plant materials will be used wherever possible to reduce the glare and solar radiation in the airport environment created by pavement surfaces and structures. Plant materials effectively prevent the glaring light from reaching a reflective surface, block the glaring light from a reflective surface, and decrease the reflective qualities of a surface.

#### 1.8.E Authority Standards

##### 1.8.E.1 Soil and Planting Beds

- Soils: The project site has been subject to considerable soil disturbance in the past. Soils analysis studies should be completed so that all variables are known. Soil testing locations will be designated on Plans. Tests for soil pH, soluble salts, and organic content, as a minimum, will be conducted for each testing location. Soil testing will be conducted by an approved soil testing laboratory. Results of the analysis and recommendations for any amendments will be provided to the Owner/Architect prior to any installations throughout the project. If soil conditions are insufficient for proper plant growth, compensation for deficiencies can be made as detailed landscape plans are developed.
- For the subject site, the following soil preparation will be completed prior to plant material installation. Inspections for soil medium verification will be strict, and must be in adherence with the following specification.
- Preparation for tree planting areas will be as follows: Trees will grow in the existing soil, but to promote quick recovery from the transplanting process, backfill will be required that contains 60% high quality, pulverized, local brown peat; 1 cubic foot of manure per 1 cubic yard of peat; and, 40% sand loam. Backfill will be placed around the balls of all new trees. Large shade trees should have pits 2 feet greater in diameter than the size of the ball. Sides and

bottoms of the pits should be scarified to increase porosity and to help root penetration into the existing soil. Care should be taken to ensure trees are planted at the proper depth, and to prevent settling of the soil. All trees should be set so that the top of the ball is 1 inch above the finished grade. For trees on sloping areas, the top of the ball should be even with the downhill side.

- Shrubs require similar bed preparation. Bed areas require a minimum excavation depth of 6 inches. The excavated soil should be removed from the site and the beds backfilled with a thoroughly mixed and prepared soil containing 1 part sandy loam, 1 part peat moss, and 1 part sharp sand. Shrub areas which occur on compacted fill should have 12 inches of prepared soil. These areas require cultivation to a depth of approximately 6 inches before tilling in a topsoil mixture. Once the bed is prepared, it should be sterilized using an appropriate method to prevent weeds and unwanted growth. Bed areas which occur on slopes greater than 3:1 should be stabilized to prevent erosion until plants are established.
- After bed preparation has been accomplished, plants should be spaced according to specifications and set with top of balls even with top of bed. Soil should be compacted carefully around each plant and watered sufficiently to eliminate air pockets around roots. A minimum 3-inch layer of pine bark mulch will be added after plants have been installed.
- Grassed and ground cover areas should have a minimum 4 inches of topsoil over regarded subsoil. Drainage is essential, so it is expedient to cultivate sand or sandy loam into the upper 4 inches of soil to permit fine grading. All areas to be grassed should be fine graded to establish a smooth, even grade, suitable for grass placement. Any undulations that cannot be raked out should be top dressed with sandy loam. Stones 1 inch or larger, sticks, roots, or other debris exposed during this operation should be removed from the site. Areas showing weed growth will be sprayed with Authority-approved herbicides, mowed, and clippings removed from grassed areas prior to final grading.
- Grassed areas which receive sod application should have sod placed so edges are touching, top dressed to fill voids with sharp sand, and rolled to eliminate undulations. The ground should be scarified as necessary immediately before sodding to provide a smooth bed. Drainage swales or channels should be protected with solid sod and/or matting as required. During construction, temporary measures should be taken to prevent erosion and sediment build-up of all drainage systems.

- Protection and Relocation of Existing Plant Materials: Protection and/or relocation of existing trees will be in accordance with City of Tampa Municipal Code Chapter 13, (10/12/89).

Table 1.3 Acceptable Plant Material for Shade Trees, Other Trees, Shrubs, Ground Covers, Vines, and Grassed Areas			
Common Name	Botanical Name	Common Name	Botanical Name
<u>Shade Trees</u>		<u>Shrubs</u>	
Live Oak	Quercus virginiana	Cast-iron Plant	Aspidistra elatior Callistemon rigidus
East Palatka Holly	Ilex opaca "East Palatka"	Rigid Bottlebrush	Ilex vomitoria nana "Schillings"
Slash Pine	Pinus Elliotti	Dwarf Yaupon Holly	Liriope muscari "Evergreen Giant"
Jacaranda	Jacaranda acutifolia	Giant Liriope	Moraea iridoides
Oriental Sweet Gum	Liquidambar formosana	African Iris	Rhaphiolepis indica
<u>Other Trees</u>		<u>Indian Hawthorn</u>	
Dahoon Holly	Ilex cassine	Crinum Lily	Crinum asiaticum
Crape Myrtle	Lagerstroemia indica	Florida Anise	Illicium anisatum
Southern Magnolia	Magnolia grandiflora	Dwarf Burford Holly	Ilex cornuta Burfordii Nana
Paurotis Palm	Paurotis Wrightii	Nandina	Nandina domestica
Senegal Date Palm	Phoenix reclinata	Oleander Calypso	Nerium oleander "Calypso"
		Split-leaf Philodendron	Philodendron selloum Zamia floridana
Canary Island Date Ligustrum Tree	Phoenix Canariensis Ligustrum japonicum	Coontie	Myrica cerifera
Cabbage Palm	Sabal palmetto	Dwarf Wax Myrtle	
Drake Elm	Ulmus parvifolia sempervirens 'Drake'	<u>Vines</u>	
Chickasaw Plum	Prunus angustifolia <sup>1</sup>	Confederate Jasmine	Trachelospermum jasminoides
Washington Palm	Washington robusta <sup>2</sup>	Coral Honeysuckle	Lonicera sempervirens
<u>Ground Covers</u>		<u>Grassed Areas</u> - St. Augustine grass ("Bitter blue" or "Floritam") Argentine Bahia	
Day Lily	Hemerocallis spp.		
Lily-turf	Liriope muscari		
Mondo grass	Ophiopogon japonicus		
Confederate Jasmine	Trachelospermum jasminoides		
Dwarf Confederate Jasmine	Trachelospermum asiaticum "minima"		
Society garlic	Tulbaghia violacea		

English Ivy Holly Fern Wood Fern Boston Fern	Hedera Helix Cyrtomium falcatum Thelypteris spp. Nephrolepis exaltata	
---	--	--

1 Not in parking lots - open areas only  
2 Investigate possibility of installing with lightning rods

### 1.8.E.2 Acceptable Plant Material

- For the purpose of unity in design, the following plant lists will form the basis of landscape design. Plant materials permitted have been selected for adaptability to existing conditions, harmony, interest in structure, texture, and ultimate growth habits. Acceptable plant materials for specific uses are shown in Table 1.3 on the following page. Shade Trees and Other Trees as listed are acceptable for use in open areas, surrounding buildings, buffer areas, and parking areas except as noted. Shrubs as listed are acceptable for use in all landscape areas. Ground Covers as listed are acceptable for mass plantings. Vines as listed are acceptable for upright growth against buildings or other structures. Any deviation from this list will require the approval of Authority's Director of Maintenance.

### 1.8.E.3 Irrigation

**Sleeving:** All irrigation-related sleeving will be PVC Schedule 40 and installed for the proposed project area so that sprinkler systems can be installed without the disruption of transportation systems. All piping used in planting areas will be PVC Schedule 40.

**Control Valves:** The control valves will be electric automatic remote control valves. All electric valves will be enclosed in concrete valve boxes. Backflow preventers will only be used when tied to a potable system.

- a. Small grassed areas which occur adjacent to roadway paving will be watered with small diameter pop-up heads so that close control can be maintained on wind spray.
- b. Flush lawn quick coupler valves will be provided in all landscape planted areas. They should be located so that all trees and planting areas can be reached by a 100-foot hose.
- c. Irrigation piping will not be installed on top of roadway slopes or along retaining wall toes unless cut-off valves are positioned at lower levels and away from structure.

---

### 1.8.E. Erosion Control During Construction

Where slopes are equal to or greater than 3:1, jute matting or fiberglass matting should be considered to protect against erosion of the topsoil or prepared soil. Drainage systems should be protected with solid sod and/or matting, as required. During construction, temporary measures should be taken to prevent erosion and sediment build-up of all drainage systems.

1.9 Site Signage and Graphics – Reserved

1.10 Access Control - Reserved

1.11 Fencing and Gates - Reserved

1.12 FAA Systems – Reserved

## **Section 2 - Architecture – Building Engineering**

2.1 Applicable Codes and Reference Standards

### 2.1.A City of Tampa Codes

The City of Tampa typically has adopted the following codes as the Development standards for building construction. The design professional should obtain a current update regarding the applicable editions and date of adoption for each code.

- Florida Building Code - Building
- Florida Building Code - Plumbing
- Florida Building Code - Mechanical
- Florida Building Code – Fuel Gas
- National Electric Code, NFPA
- Life Safety Code, NFPA 101
- Flood Plain Regulations, Chapter 5-111
- Florida Fire Prevention Code
- Historic Preservation Standard
- Chapter 5, Building and Construction Regulations
- City of Tampa Code of Ordinances

In addition to the above codes utilized by the Building Department, the Fire Marshal's office also references the Standard Fire Prevention Code and any applicable National Fire Code (NFPA).

The designer will consult with the appropriate building department outside the City of Tampa when the project is at Plant City Airport or at Vandenberg Airport. Consult the City of Plant City, Florida, Building Department or the Hillsborough County Building Department, respectively.

## 2.1.B Accessibility Codes

The current accessibility code in Florida is titled Florida Accessibility Code for Building Construction; and it is included in the Florida Building Code as Chapter 11. The introduction addresses the relationship of the Code to the Americans with Disabilities Act of 1990 and the ADA Accessibility Guidelines (ADAAG). The code includes the Appendix of ADAAG, instructions regarding a waiver of accessibility requirements, and other pertinent items.

Additional provisions are also included in the Florida Statutes, Title XXXIII, Chapter 533, Building Construction Standards, Part II, Accessibility by Handicapped Persons (ss 553.501-553.513.)

## 2.1.C State of Florida Codes

### 2.1.C.1 Florida Statutes, Chapter 553, Building Construction Standards Currently Includes: Florida Statutes, Title XXXIII, Chapter 533, Building Construction Standards

Part I	Plumbing
Part II	Electrical Code
Part III	Glass
Part IV	Factory – Built Housing
Part V	Accessibility for Handicapped-Persons
Part VI	Trench Safety
Part VII	State Minimum Building Codes
Part VIII	Thermal Efficiency Standards
Part IX	Energy Conservation Standards
Part X	Standards for Radon – Resistant Buildings
Part XI	Building Energy – Efficiency Rating System

### 2.1.C.2 Florida Administrative Code

Chapter 61C-5, Florida Elevator Safety Code, Department of Business and Professional Regulation.

## 2.1.D National Codes

ACI 318 - (applicable edition), Building Code Requirements for Structural Concrete

ASHRAE/IES 90.1 (applicable edition), Energy Efficient Design of New Buildings except Low-Rise Residential Buildings.

CPSC 16 CFR Part 1201, Architectural Glazing Materials, Federal Register

ANSI/ASME A17.1 - 1993 and ASME A17.1a - 1994, the "Safety Code for Elevators and Escalators" are incorporated by reference with paragraph 3003.1.1, SBC - 1994. Chapter 4A - 47 (listed above) also makes reference to this code. A17.1b - 1995 has been published, but the SBC has not yet made reference to it.

The design should carefully review all applicable codes and their referenced codes and standards. When a conflict between two codes is discovered, the prudent designer would conform to the most stringent requirements.

#### 2.1.E Reference Standards

### 2.2 Building Objectives - Planning Criteria

#### 2.2.A Typical Facility Objectives

##### 2.2.A.1 Geotechnical

##### 2.2.A.1.1 Building Area

Previous Foundation History: A variety of structural foundation types have been used at TIA, including the following:

- a. Landside Terminal Building (1971): This building is supported on both steel pipe piles and spread footings, bearing on rock at willow rock locations. A boring was drilled at each column location. At one column location, excessive settlement was experienced, resulting from solution activity in the limestone bedrock under a spread footing at that location. The settlement initiated when three levels of the garage were added in 1982. About two inches of settlement occurred and large quantities of grout had to be pumped into the solution void to stabilize the foundation. Grouting quantity could not be predicted in advance.
- b. The foundation systems utilized for the original four airside (1971) vary. Airsides B and C were built on pile foundations; Airsides D and E were constructed on willow spread footings. The foundations of the shuttle (AGT) system hammerhead pier and maintenance area/platforms for all four original airside were constructed with pile foundations.
- c. Taxiway "J" Overpass (1971): Spread footings on limestone were used.
- d. Airside F (1987): Spread footings, in combination with a grouting program, were used. A boring was drilled at each column location. Grouting quantities were substantial and could not be accurately predicted in advance.

- e. Airside F AGT System Guideway Piers (1987): Drilled shafts were used. Final lengths were determined by a boring taken at each drilled shaft, plus observations during the shaft drilling operations.
- f. Quad Deck Expansion on East and West Sides of Terminal Building (1987): Drilled shafts were used. Final lengths were determined by a boring taken at each drilled shaft, plus observations during the shaft drilling operations.
- g. Long Term Parking Garage (1991): Drilled shafts were used. Final lengths were determined by a boring taken at each drilled shaft, plus observations during the shaft drilling operations.
- h. Airside A (1993) was constructed utilizing 30", 36", 42" and 48" diameter drilled piers as the foundation system. The AGT maintenance platforms and the passenger loading bridge pedestals were constructed on 48" diameter drilled shafts.
- i. Airside E (2002) was constructed utilizing spread footings. The AGT maintenance platforms and the passenger loading bridge pedestals were constructed on 48" diameter drilled shafts.
- j. Airside A Outbound Baggage Sortation Facility (2003) was constructed utilizing 48" diameter caissons under all columns and strip footings under the exterior masonry walls.
- k. Airside C (2005) was constructed utilizing spread footings. The AGT maintenance platforms and the passenger loading bridge pedestals were constructed on 48" diameter drilled shafts.
- l. Remote Parking Garage (2005) was constructed utilizing 30", 48" and 60" diameter drilled piers (caissons). The administration building was built on spread footings.

New Foundations: Because of the uncertainty of the limestone bedrock consistency, drilled shafts or piers have been the most prevalent foundation system in recent years. Airside E was, however, a notable exception; it was constructed on willow spread footings.

The foundation system options must be considered on a site by site basis after an extensive geotechnical investigation.

If a deep system is required, the choices include drilled shafts, piers, or caissons and auger cast piles. Mechanically driven pile systems are not allowed with close proximity of the Landside Terminal Complex.

Geotechnical Investigation: As a minimum, the following guidelines will be observed in the design investigation.

- a. Minimum boring grid will be 200 feet on center.
- b. Borings and testing locations will carry airport grid coordinate locations and ground surface NGVD elevations.
- c. Minimum boring depth will be 50 feet, including 20 total feet into refusal (N=50+ blows/ft) limestone material.
- d. Testing locations, procedures, and times of testing will be established well in advance of testing, and must be coordinated with the Authority. Test locations will be cleared for utilities by the Design Consultant, the Authority, and affected utility companies. All areas disturbed by testing must be restored to the satisfaction of the Authority.
- e. Sufficient field and laboratory testing will be performed to establish classifications and properties for the various strata encountered. This will include determination of Unified Soil Classifications, plasticity/consolidation properties of compressible materials, bearing values, strength properties, and groundwater conditions.
- f. Design phase load test programs will only be considered after completion of a preliminary geotechnical program, a preliminary foundation analysis, and a cost study justifying the load test program.
- g. Foundation selection will address vibration and disturbance to adjacent structures, noise, and annoyance levels, cost, risk, and constructability.

Earthwork: Specific recommendations will be made for the project needs in the areas of clearing and grubbing, undercutting, proof rolling, embankment construction, suitable materials, compaction, stabilization, subgrade preparation, and any special procedures that may be proposed.

Related Sections:

3. Civil, Roadway, and Airfield
5. Utilities
7. Structural
8. Mechanical
9. Electrical
10. Landscape and Irrigation
12. Elevators

Code Requirements:

- a. Geotechnical testing will conform to applicable sections or ASTM Volume 04.08, "Soil and Rock; Building Stones; Geotextiles."
- b. Geotechnical testing and engineering will be conducted by corporations and experienced individuals licensed to practice this specialty by the State of Florida.

#### 2.2.A.2 Structural – Reserved

#### 2.2.A.3 Architectural

##### 2.2.A.3.1 Glare Control or Prevention

- Use roof overhangs, tinted glass, coated glass, fritted glass or applied films to control glare and reduce heat gain from the sun.
- Exterior sunscreens are generally not allowed because they provide a roosting area for birds. Reflective-type glasses are generally not considered because of the possibility of creating high intensity reflections that might temporarily cause blindness to pilots during aircraft operations.
- Consider glare patterns in the placement of light fixtures. High contrast "scallop" can be created on walls or sign faces as a result of poor fixture placement. When preparing reflected ceiling plans, show all ceiling-hung signage elements so that lighting patterns and glare potential may be reviewed. Avoid placing lighting adjacent to ceramic tile walls; the "wash" of light accentuates irregularities that are common with such a finish.
- Avoid products or conditions that can create navigation hazards. Finishes such as metallic paints can cause visual reflections and even radar interference. Sloped glass areas can cause reflection problems.
- High intensity exterior lighting fixtures will be selected that include appropriate shielding or cut off provisions to eliminate glare to roadway and walkway areas.

##### 2.2.A.3.2 Noise and Vibration Control

- Provide for isolation joints between slab areas and between slabs and columns. This isolation will be designed to prevent the transmission of low frequency vibrations from main

mechanical rooms that contain chillers, compressors, and pumps.

- Provide localized isolation for pumps, air handlers, and so forth. Consider inertia pads.
- Install sound attenuation devices on ductwork and provide acoustic treatment in air plenum areas.
- At baggage sortation areas, provide vibration isolators at all conveyor system suspension elements. Consider a sprayed-on insulation product on the bottom side of all elevated slabs for thermal and sound absorption purposes.

#### 2.2.A.3.3 Passenger Circulation and Travel Distance

- Endeavor to maintain a maximum 700-foot walking distance from the passenger's parked car to the door of the aircraft.
- Understand the influences of the types of passenger flow as follows:

Enplaning passengers: “Trickle flow” describes the arrival rate for departing passengers. The earliest passengers arrive an hour or more before departure, and the arrivals continue a few at a time every few minutes until departure.

Deplaning passengers: “Slug flow” describes the 200-300 passengers arriving through a single doorway within a five- to ten-minute time period.

- Maintain a 30-foot minimum clear width for a double loaded concourse walkway.
- Position passenger check-in counters so they are set back a minimum of 16 feet from the edge of the concourse walkway to accommodate the passenger queue. By setting the check-in counter at a  $\pm 60$  degree angle relative to the concourse walkway, the available queuing area can be increased. The angular placement of the counter also provides improved sight lines for the gate number signage on the check-in counter back wall. (See 2.2.B.1.6, 2.2.B.2.2, and 2.2.B.2.3 for notes regarding ticket counter and back wall design.)
- Arrange seating and check-in counters to create separate enplaning and deplaning aisles within each holding area. Provide a direct gate to walkway alignment for deplaning aisle.

Locate the enplaning aisle parallel and adjacent to the outside wall.

- Provide stairs adjacent to up and down escalators as a backup system when the escalator(s) may be out of service. Minimum escalator tread width will be a nominal 40 inches to accommodate a single passenger with carry-on baggage.

#### 2.2.A.3.4 Building Occupant Load and Miscellaneous Code Issues

With the 1991 edition, the Life Safety Code, NFPA 101, began to recognize the unique occupancy conditions associated with airport terminal buildings. Table A.7.3.1.2 provides airport terminal load factors to assist in calculating the occupant load.

Table A.7.3.1.2 (NFPA 101-2000) Airport Terminal Occupant Load Factors	
Airport Terminal Area	Area/Person
Concourse (circulation area)	100 sf / person
Waiting areas (seating areas)	15 sf / person
Baggage Claim	20 sf / person
Baggage Handling	300 sf / person

Other terminal space occupant loads that have been generally agreed to by the City of Tampa Building Department and Fire Marshal includes:

Gift shop (mercantile)	60 sf / person
Lounge / restaurant (small assembly)	15 sf / person
Airline operations (business)	100 sf / person
Storage	300 sf / person
Mechanical / Electrical (storage)	300 sf / person
AGT Maintenance (storage)	No occupant load
Toilet Rooms	No occupant load
Elevators, escalators, and stairs	No occupant load

Section 12.2.3.3 includes Exception No. 2 which allows exits to be distributed around the perimeter of the building. Exiting distances become more workable, but most of the exit doors must now be equipped with special delayed release locking hardware to maintain aircraft operations area (AOA) security. In Airsides F, A, E, and C, exterior exit stairs are provided at frequent intervals around the building perimeter. These stairs are served by exit doors with

delayed release exit hardware that is interfaced with an access control system based on a computer/identification badge program. Section 7-2.1.6, provides the guidelines for this operation (refer to subsections 2.2.A.3.5 and 2.2.A.3.6 for the functional features of the access control system and the delayed action fire alarm system).

In addition to the interior and exterior exit stairs, the elevated emergency walkway between the AGT guideways has been recognized as an acceptable exit, or area of refuge. Other potentially applicable NFPA fire codes include (but are not limited to) the following: NFPA 1, Uniform Fire Code, NFPA 10, Standard for Portable Fire Extinguishers; NFPA 13, Standard for the Installation of Sprinkler Systems; NFPA 20, Standard for the Installation of Stationary Pumps; NFPA 30A, Code for Motor Fuel Dispensing Facilities and Repair Garages; NFPA 70, National Electric Code; NFPA 72, National Fire Alarm Code; NFPA 80, Standard for Fire Doors and Fire Windows; NFPA 88A, Standard for Parking Structures; NFPA 92B, Standard for Smoke Management Systems in Malls, Atria, Large Areas; NFPA 96, Standard for Ventilation Control and Fire Protection of Commercial Cooking Operations; NFPA 105, Standard for the Installation of Smoke Door Assemblies; NFPA 110, Standard for Emergency and Standby Power Systems; NFPA 111, Standard for Stored Electrical Energy Emergency and Standby Power Systems; NFPA 130, Standard for Fixed Guideway Transit and Passenger Rail Systems; NFPA 221, Standard for Fire Walls and Fire Barrier Walls; NFPA 241, Standard for Safeguarding Construction, Alteration, and Demolition Operations; NFPA 407, Standard for Aircraft Fuel Servicing; NFPA 409, Standard for Aircraft Hangars; NFPA 415, Standard for Airport Terminal Buildings, Fueling Ramp Drainage, Loading Walkways; and NFPA 780, Standard for the Installation of Lightning Protection Systems.

NFPA 415, Section 2-1.5, addresses architectural features that may be required if potential fuel spill points (such as fuel hydrant boxes) are located less than 100 feet horizontally from glazed building walls. Section 3-1.1 addresses minimum ramp slopes away from terminal buildings.

Relatively obscure code provisions can create difficulties for designers if they are not considered in the early schematic phase of a project. NFPA 415, Section 2-2.2, restricts the placement of exhaust outlets, or air intakes, on the aircraft ramp side of the building. Openings will not be less than ten feet above grade level of the ramp.” This provision has required several creative solutions to accommodate kitchen makeup air and exhaust, and tenant area toilet exhausts.

### 2.2.A.3.5 Access Control System (ACS)

In compliance with Transportation Security Administration (TSA) Part 1542, the Authority has an Airport Security Program incorporating the use of a computerized Access Control System (ACS). The ACS software (CCure800) and processing panels are manufactured by Software House. This ACS controls select doors and gates throughout the airport terminal complex and airfield.

The system has the capability to:

- Ensure that only those persons authorized to have access to secured areas are able to obtain that access.
  - Deny access immediately at the access point(s) to individuals whose authority to have access changes.
  - Differentiate between persons authorized to have access only to a particular portion of the secured area or to the entire secured area(s).
  - Restrict an individual's access by time and date.
- 
- Upon authorization, security training, and an FBI background check, employees of the airport, tenants, or contractors may be issued an Airport Identification Badge that incorporates a uniquely identifiable electronic code. When the proximity badge is presented to the badge reader at either side of the door or gate, the system confirms access authorization according to the particulars previously entered into the individual's computer record.

In addition, select components of the Access Control System have been installed in other non-secure access points (i.e., Authority Offices). For these doors, exit activation of the door release mechanism is usually controlled by a motion sensor and/or panic hardware.

The ACS host computer is located in the Communications (Comm.) Center. The access status of each employee is programmed into the system by way of a terminal located in the Operations Department. Comm. Center personnel monitor the system's operation and report alarm conditions to the Airport Police Department. At many portals, an alarm condition initiates a video scan of the location that can be recorded and reviewed.

The ACS host computer is networked with processors which are located at each airside building through a fiber optic conductor network. From these processors, the network is distributed to local processors, which generally are located in nearby mechanical or electrical spaces that can support four door openings. At doors, power supplies and timer modules interface with either electromagnetic locks or electronic panic devices to provide controllable access through the portal. At gates and turnstiles, the card reader interfaces with contacts to start a gate operator or release a turnstile.

Access-controlled building doors are also interfaced with the fire alarm system to allow a complete release of all doors in the event of general building alarm activation.

#### 2.2.A.3.6 Closed Circuit Television (CCTV) System

The Airport utilizes CCTV for various security and operational purposes. The system transmits video via coaxial and fiber optic cable. The CCTV cameras consist of pan/tilt/zoom and fixed mount lens type that redesigned for both interior and exterior environments. Video is transmitted back to the Airport Communications Center where by the cameras can be controlled through video switchers located in Airport Operations, the Airport Police Department, and the Communications Center. Many cameras and associated video signals are linked to the access Control System that displays video upon a generated alarm. All CCTV cameras are digitally recorded on a 24-hour basis.

Typical areas with CCTV monitoring include:

- Passenger screening areas at the airside
- Airside concourses and exit doors.
- AOA turnstiles from the truck court (at the airside)
- AOA vehicle gates (at the truck courts and around the airfield)
- At the monorail and shuttle stations (at the airside, at landside, and in the Long Term Garage)
- At entry/exit doors at baggage makeup areas (AOA);
- And at many other selected areas

- The CCTV system continues to expand. A designer must meet with the Operations and Police Departments to establish and confirm the definitive needs for a particular project

#### 2.2.A.3.7 Federal Inspection Services (FIS) Security

- In Airside F, a second door security system is installed to maintain a sterile accessway for arriving international passengers. At each of the international arrival ramps, a door interlock has been created with a pair of doors above and a pair of doors below the loading bridge entry/exit door. An electromagnetic lock system allows for only one pair of doors to be open at one time. The locking arrangement is controlled by key switches operated by an airline gate agent. In the most frequently used condition, the domestic mode, doors above the loading bridge door (located between the holdroom and the loading bridge door) are held open by energized electromagnetic door holders (their electromagnetic locks are de-energized). The second pair of doors below the loading bridge door is locked with electromagnetic locks preventing access to the lower level FIS processing area.
- When an international flight is due to arrive, the gate agent resets the key switch reversing the locking arrangement. The electromagnetic holders on the upper doors are de-energized which allows the doors to close against an energized electromagnetic lock. The upper doors are then secure. As a result of the same key switch operation, the magnetic locks on the lower doors are de-energized which allows them to open. As the passengers move down the ramp, the doors can be opened and then held open by the electromagnetic holders which are now energized. When the last passenger passes through the lower door opening into the FIS screening area, the gate agent activates another key switch which resets the interlock to the domestic operation mode.

#### 2.2.A.3.8 Fire Alarm Pre-Signal System

With the activation of a pull station, smoke detector, heat detector, or sprinkler flow switch, an audible signal and visual display are indicated at the local building annunciator and at the Comm. Center. An alphanumeric display is illuminated on the fire alarm control panel, a graphic representation appears at the “satellite” annunciator at the airside, security office, and the fire control rooms, and a user-defined English language description is transmitted to the Comm. Center CRT displays and line printers. Activation of a duct detector on an air handling unit will immediately shut that unit down. Additional HVAC control sequences may occur as a result of building control system programming. A local indicating lamp will light at locations of the area detector or duct detector initiating the alarm.

Upon activation of any elevator lobby, elevator machine room, or elevator hoistway smoke detector, Phase I recall will be initiated at that elevator (or bank of elevators), and the elevator car will return nonstop to its designated service level where the doors will open and remain open. The “Do Not Use Elevator” lamp will illuminate at the designated level.

Upon activation of an elevator machine room or elevator hoistway heat detector, the system will shunt trip the elevator controller operating power after the above recall event has successfully landed the elevator at the appropriate level and opened the doors.

Once the alarm is displayed, the Comm. Center notifies the airport police dispatcher of the alarm and an officer is dispatched to assess the alarm condition. If within a five-minute time period, the alarm is determined to be false, the system will reset and all functions will return to normal. If the alarm is verified as valid, the officer immediately advises the Comm. Center of the details and a general alarm is initiated.

At a general alarm, the City of Tampa Fire Department is notified (apparatus will be dispatched), a contact closure is made with the access control system, and all delayed-action door operators are immediately released. One of several prerecorded messages is broadcast over the annunciator speaker system, and the strobes begin to flash.

In the event the police officer is unable to complete alarm verification within the five-minute pre-signal period, a general alarm is initiated and all operations previously mentioned will occur.

---

### 2.2.A.3.9 Shunt-Trip Operation, Building Power, and AGT Power

Power feeds for both the airside building and its AGT system generally occur on the airside end of the AGT route. Typically, each system has its own switchgear room with dedicated transformers and switchgear. The buildings use 277V/480V, and 120V/208V systems, and the AGT system is typically 600V.

As a life safety precaution, the Fire Marshal has required the capability of de-energizing both power systems from either switchgear room. Typically, the local switchgear can be de-energized with a few disconnect pulls. In order to de-energize the entire building and the guideway, shunt trips for the other system will be located on the switchgear room wall, within steps of the main gear disconnects.

### 2.2.A.3.10 Tempered Glass

Shortly after opening in November 1987, Airside F experienced a large amount of spontaneous tempered glass breakage that was essentially due to nickel sulfide intrusion. The problem became so severe that the facility was ultimately completely reglazed with laminated glass. Apparently, the quality level of tempered glass in the mid 1980s deteriorated to such a degree that the industry as a whole began to discourage its use.

As a result of the Airside F difficulties, the Authority now specifies that all areas requiring safety glass (per Florida Building Code, Chapter 24) will be finished with laminated glass. The only exception might be the use of 1/4-inch clear tempered glass for infill in “normally-sized” storefront entrance doors.

For exterior purposes, Airside A used a 1-foot, 8-inch-high curb to eliminate the safety glass requirement, and 9/16” thick laminated heat-strengthened glass to achieve the strength necessary to achieve the opening sizes desired.

Airside E: (All Viracon Products)

Type 1:       9/16” laminated VH 13075, HS/HS  
                  1/4” clr with VE-1-85 coating, #2  
                  .060” PVB interlayer  
                  1/4” gry

Type 2:       9/16” laminated VH 13-75 HS/HS spandrel  
                  1/4” clr with VE-1-85 coating, #2

- .060" PVB interlayer  
 ¼" gry with V907LF blk, #4
- Type 3: 9/16" laminated VH 13-75 HS/HS  
 ¼" clr with VE-1-85 coating, #2  
 .60" PVB interlayer  
 ¼" gry with V907LF blk, pattern 5006, #4
- Type 4: 1" insulated glass, Low E, HS/HS  
 ¼" gry with VE-3-2M coating, #2  
 ½" air space  
 ¼" clr
- Type 6: 1" insulated glass, Low E, HS/HS  
 ¼" gry with VE-3-2M coating, #2  
 ½" air space  
 ¼" clr with V907LF blk, pattern 5006, #4

Curtain wall and storefront systems:

Kawneer 1600, nominal 2 ½" x 7"  
 Kawneer Tri-fab 450, nominal 1 ¾" x 4 ½"

Specialty long span truss curtain wall system:  
 Advanced Structures, Inc. Marina del Rey, CA.

Airside C: (All Viracon Products)

- Main glass: 1" insulated glass, Low E, HS/HS  
 ¼" Evergreen with VE-8-2M coating, #2  
 ½" air space  
 ¼" clr
- "A" glass: 1" insulated glass, Low E, HS/HS (appears "frosted")  
 ¼" Evergreen with VE-8-2M coating, #2  
 ½" air space  
 ¼" clr SK/P V1086 S1M SANDBLAST #3  
 SCRNP1 3058 #3
- "B" glass: 1" insulated glass, Low #, HS/HS (appears "frosted")  
 ¼" Evergreen with VE-8-2M coating, #2  
 ½" air space  
 ¼" clr SLK/P1 V185 S11M ACID ETCN #3  
 SCRNP1 3058 #3
- "C" glass: 1" insulated glass, Low E, HS/HS (fritted)  
 ¼" Evergreen with VE-8-2M coating, #2  
 ½" airspace

¼" clr SLK/P1 v175 lf opaque white #3  
 SCRNP1 5006 #3

"D" glass: 1" insulated glass, Low E, HS/HS  
 ¼" gry with VE-3-52 coating, #2  
 ½" air space  
 ¼" clr

"5D" glass: 1" insulated glass, Low E, HS/HS (spandrel)  
 ¼" gry with VE-3-52 coating, #2  
 ½" air space  
 ¼" clr APD/P1 V175 LF (opaque wht) #4

"E" glass: 1" insulated glass, Low E, HS/HS (spandrel)  
 ¼" Evergreen with VE-8-2M coating, #2  
 ½" air space  
 ¼" clr

"G" glass: 1" insulated glass, Low E, HS/HS  
 ¼" clr with VE-1-2M coating, #2  
 ½" air space  
 ¼" clr

Curtain wall System:

Vistawall: Several frame configurations, 2 ½" wide X 6 ½", 7 1/4",  
 8 ½, and 12 ¼" deep

Interior Tempered Glass System:

RDM Glass Systems (Inkan Limited), Ontario, Canada:  
 ½" and ¾" glass panel system with 14" fins.

2.2.A.3.11 Maintenance Contracts

For nearly 30 years, the Authority Maintenance Department has maintained exclusive service contracts with various equipment and system manufacturers. Over the years, these contracts have resulted in competent regularly scheduled preventative maintenance, and in several cases, full-time, on-site representation for emergency maintenance. Current service contracts include:

Bombardier	for airside to landside AGT systems for monorail system at the Long Term Garage
ASIG	for hydrant fuel system
Bombardier	for monorail system at the Long Term Garage
Carrier	for chillers (building/preconditioned air)

	and chilled water systems
Com-Net	for EVIDS System
Johnson Controls	for building control system (Metasys - EMCS)
Schindler	for elevators, escalators, and dumbwaiters
Simplex	for fire alarm system

2.2.A.3.12 Toilet Room Design

Fixture Counts: With the construction of Airsides F, A, E, and C, the CAA has exceeded the minimum standards for fixture counts as listed in the Florida Building Code-Plumbing (FBC-P). The increased fixture quantities have been developed in response to estimated slug load passenger counts at the terminal's peak load condition. The designer will review any updates to the passenger loading forecasts before finalizing any toilet facility modifications. The designer will also refer to the FBC-P, Paragraph 403.1.1, for special male/female fixture ratios associated with assembly occupancies. (potty parity)

Entry Detailing: Typically, a semi-circular maze arrangement is used, with carpeted wall for acoustical control (without doors). The minimum clear width will be 5 feet. The maze floor is typically carpeted, and a marble threshold transitions to ceramic tile upon entering the toilet room.

Finishes: Walls, within the toilet room, are typically clad full height with ceramic tile (minimum size is 4 inches by 4 inches), with 1/8 inch maximum joints, and gray grout. Floors are also ceramic tile (minimum size is 8 inches by 8 inches), with 1/4 inch or smaller joints, and gray grout. Ceilings will be painted gypsum wallboard.

Minimum Circulation Clearances: Toilet stall to front face of lavatory will be 5 feet, 6 inches; toilet stall door to toilet stall door will be 6 feet; front face of lavatory to front edge of urinal will be 6 feet, and a minimum walkway clearance will measure 5 feet.

Toilet Partitions, Toilet Accessories, and Toilet Fixtures/Fittings: The Authority maintains strict and well-defined standards for these components. Refer to Sections 3.10.A, 3.10.E, and 3.15.F, for a detailed listing of the respective Authority standards.

Trash Receptacles (in toilet rooms): A trash receptacle (R) must be placed adjacent to one edge of each lavatory (L). A typical configuration at a lavatory wall would be: L-R-L-L-R-L. In addition, a receptacle is to be placed on each side of the entrance/exit doorway.

Diaper Changing Facilities: Each toilet room (both men and women) will be equipped with a diaper changing area. A counter with an integral sink will be fabricated of Corian (or equal) and will have a raised front edge. The counter will have a minimum length of 6 feet, and the sink will be placed at one end, leaving a 4-foot clear shelf width. The counter depth will be 2 feet. Counter detailing will make ADA compliant accommodations for individuals with disabilities. Adjacent toilet accessories will include a towel dispenser, a soap dispenser and a waste receptacle.

Women's Vanities: Each woman's toilet room will be provided with a "makeup" vanity counter, fabricated from Corian (or equal). Length can vary from 8 feet to 16 feet, depending on toilet room capacity. Counter depth will be 1 foot. A full width stainless steel-framed mirror will be installed above the counter to a height of 6 feet, 6 inches, approximately. A duplex outlet will be provided for every 6 feet of counter length.

Mirrors: All mirrors will be framed in stainless steel. Each women's toilet must be equipped with a 24-inch by 60-inch-high, full length mirror, mounted 1 foot above the floor.

Companion/Family Toilets: At each large toilet room grouping, provide a separate private toilet room that is accessible by an individual with disabilities (of either sex), who requires assistance from a spouse, nurse, or companion. The room should be at least 80 square feet in area. Corian (or equal) shelves will be provided for baggage and diaper changing. All plumbing fixtures installations will be ADA compliant. A junction box for an emergency call system will be roughed in, between the toilet and lavatory, at a height of 1 foot, 4 inches above the floor. All finishes and accessories will be consistent with standard toilet room construction.

Plumbing Chase Design: All plumbing chases will be designed to provide a minimum clear access walkway, 2 feet, 6 inches wide by 6 feet, 6 inches high, between the fixture carriers. Such a space is necessary to access and service the electronic flush valves, the electronic faucets, all fixture traps, waste line cleanouts, and water service branch isolation valves. Chases will be accessible from outside the toilet room such that a female plumber can service a men's room fixture, or vice versa. A 3'-0" wide door will be provided for access. Floor drains must be provided at each lateral cleanout location. A waterproofing membrane will be installed on all chase floors. The membrane will be turned up the perimeter wall a minimum of 2" to create a "mini-sump". Appropriate linear fluorescent fixtures will be provided to effectively illuminate any serviceable area. The light will be switchable at the chase door. Duplex outlets must be

provided at 20 feet on center. All piping penetrations through elevated floors will be waterproofed. All valves within the chase will be located at or beneath 7 feet above the floor.

Floor Drains: Floor drains will be located frequently within the toilet room; allow one drain for each 500 square feet of floor area. Drains will be located near the wall and between fixtures, or under toilet partition sidewalls. The drain placement will be away from any traffic areas (refer to chase requirements listed previously)

Cleanouts: Waste cleanouts will be placed at the end of each fixture bank lateral.

Janitors Closet: All closets will include a floor sink and a mop holder. Walls abutting the sink will be clad with ceramic tile (4" x 4" minimum size) to a height of 6' - 0" and a width of 1' - 4" beyond the sink edge. The mop holder will be installed in a position that will allow the mop to drip into the floor sink.

Walls beyond the tile areas will be painted gypsum wallboard to a height of 8' - 0". All plumbing lines and electrical conduit and junction boxes must be concealed behind the wallboard. The remainder of the space, above 8' - 0" can remain unfinished with exposed studs, conduit, piping, valves, etc.

#### 2.2.A.3.13 Housekeeping Facilities

Vacuum cleaner outlets, 20 amp/120v, hospital-grade, will be located in carpeted areas within 100' of any point within that area. Breakroom facilities will be provided for the housekeeping staff that includes a counter with a sink, a microwave oven, a refrigerator; other furnishings within the space may include a rectangular table (seating 6) and a desk and chair. Thirty-to-forty half lockers, 12" wide x 36" high x 16" deep, will be provided for storage of personal items. Lockers will have a padlock hasp.

#### 2.2.A.3.14 Bird Control

Building designs will discourage the roosting of pigeons and other nesting birds by minimizing the amount of ledges and protected surfaces where nesting might occur. The building envelope will be sealed as necessary with grilles, screens, etc., to prevent bird entry. In areas where the design may create a roosting area, a proven means of discouraging birds will be used; such as low-voltage wiring strips along parapet walls, low-visibility nylon lines crossing the areas, nylon netting around cooling towers, etc.

## 2.2.A.4 Equipment/Furnishings

### 2.2.A.4.1 Ash/Trash Receptacles

The construction of Airside A prompted the development of new receptacle that has been repeated on many subsequent renovations. The stainless steel unit can be fabricated with a sloped top or a sand tray (smoking areas). Typically, it is fabricated with a wall-mounting bracket. The piano-hinged access door has a concealed latch and an integral raised lip receptacle shelf. A removable cylindrical galvanized receptacle sits on the shelf.

### 2.2.A.4.2 Telephone Kiosks

During the construction of Airside A, a "pin-wheel" five station telephone kiosk unit was developed. This unit has subsequently been repeated in other renovation projects. The carpet accented stainless steel unit includes four conventionally accessible sit down telephone modules and one wheelchair accessible module with TDD equipment. A telephone termination cabinet is located between two partitions and an airport page phone is installed on the access door. Duplex outlets for computer power are installed adjacent to each phone unit. Ashtrays are installed in the countertop beneath each phone when the unit is installed in a smoking area.

- When Airside E was constructed, the budget did not allow the use of the custom unit described. A standard production system manufactured by Phillips & Brooks/Gladwin was utilized. These units were also equipped with duplex outlets, TDD equipment and Internet access ports (Power Oasis terminals).

### 2.2.A.4.3 Landside Ticket Counters

During 1999-2000, a project was initiated to replace the airline ticket counters on the Ticket Level. The resulting shell configuration consists of stainless steel clad end pylons bridged by a solid surface cowling to conceal the computer monitors. Two solid surfaces are overlaid on stainless steel clad front panel. This has an overall width of 6' - 0".

Stainless steel clad bag wells are placed on each side of a ticket counter module. The "floating" top design for the bag well allows for the installation of electronic scales on an as-needed basis. Digital readouts are provided on the cowling ends on each side of the bag well. The typical width of a bag well is 3' - 0". On the agent side of the counter line, the shell is filled with an insert cabinet that is

generally designed and built to the particular airlines specifications. Typically, the insert design and detailing reflect the functional needs of the airline including the after hour security of ticket and bag tag stock. The design has generally evolved from work flow and ergonomic studies.

Shortly after the ticket counter replacement project was completed, the airlines began replacing many of the manned ticket counters with customized self-service E-ticket units. Many airlines installed a “corporate-standard” full height pedestal units, while others have chosen to install a small drop-in CRT module into a modified Authority counter shell. To date, the airlines have been generally receptive to making minor material adjustments to ensure visual compatibility with the Authority standard counter design. Most units are utilizing stainless steel and solid surface cabinetry.

#### 2.2.A.5 Conveying Systems

Elevator entrance design has become a somewhat complex problem. The arrangement of up to ten distinct elements that may be necessary at an elevator entrance requires research and coordination with the elevator vendor, and numerous other subcontractors. The six items typically installed by the elevator installer include the call button unit (with or without the key switch), the hall lantern (indicating direction of travel), the current floor indicator (above the door), the fireman’s phone outlet, the emergency sign explaining firefighter’s operation, and the “Do not use elevator when flashing” signal light. In addition, other signage elements are required: a directory sign (that indicates the spaces accessed on the other floors via this elevator), an “In case of fire” sign, possibly a wall bumper (in a service corridor) and possibly a tenant requested sign (intended to provide instructions to flight crew members).

At airside buildings, it is frequently necessary to equip an elevator with special access-control control components to prevent the unauthorized access to a secure level of the building by the general public. The most frequently used controls are proximity cards (which require an interface with the airport’s access control computer) or a digital keypad. A reprogrammable digital keypad can be programmed to a “corporate” code that will allow out-of-town flight crew members to access the airline’s operations areas.

### 2.2.A.6 Miscellaneous Structural Considerations - Reserved

### 2.2.A.7 Miscellaneous Plumbing Requirements

Provide ½-inch water stub up and 2-inch sewer stub up for electric water coolers (typically a tenant provided item). The designer should consult with each tenant regarding the desire and need for water coolers.

Prepare waterproofing details for all piping penetrations through elevated floor slabs. Coordinate with fire safety system.

All public toilet rooms will have 24 volt electronic flush valves on water closets and urinals and electronic faucets with blended water at lavatories.

Provide access panels when it is necessary to conceal a valve or other device that may require service or adjustment. Generally, it is preferred to locate such devices within service spaces, such as janitor closets, or plumbing chase, where they can be directly accessible. The components should be located within 7 feet of the floor (accessible without a stepladder). If an access panel is required in a tiled wall, it will be fabricated in stainless steel.

Provide frequent placement of cleanouts (particularly at changes of direction) in all underground storm, sanitary, grease, and specialty waste lines.

Provide tenant sub-meters on each tenant water service line. Meters must be accessible for monthly readings (accessible without a stepladder).

Provide a separate city water meter for cooling tower makeup water and cooling tower blow down. Meters must be purchased from the City of Tampa.

All "P" traps, shutoff valves, and faucet electronics will be located inside the plumbing chase.

All watercloset and urinal flush valves will be located in the plumbing chases.

Electric water heaters (EWH) will be roughed-in (plumbing and electrical) so that they can be easily removed and replaced without unsoldering or cutting piping. Locate adjacent to a floor drain.

Install gate valves immediately adjacent on either side of any pressure-reducing valve. Install pressure reducing valves in an accessible area below 7' - 0" above finished floor.

Install domestic water isolation valves on branch lines 2" and larger.

Coordinate floor drain locations with structural framing.

Do not install storm, sanitary piping, drainage piping, or HVAC pans or piping directly over electrical equipment, including panels. Do not run pressurized liquid (domestic water, chilled water, etc.) piping through electrical rooms.

Design water supply system for toilet rooms with valve zones so that only a small portion of the room must be shut down to service a particular component.

Install floor drains with trap primers and hose bibbs in all mechanical rooms.

All piping and conduit will be concealed in all finished interior spaces and on the exterior of the building.

Design domestic water pumps, so that one pump can be mechanically and electrically isolated to enable the other pump to remain operational (100% redundant and alternating function). Provide a full size bypass line on the domestic water system downstream of the booster pump package.

Provide a duplex in-line filter/strainer on the inlet to the domestic water pump.

Provide conductivity monitoring sensor on incoming city water and interface with BCS (METASYS).

Install gate valves immediately adjacent on either side of an air separator or a pressure reducing valve.

Provide cleanouts at the top of all sanitary risers. Provide cleanouts at the ends of all laterals and at all sanitary drops. Provide cleanouts at the end of all branch lines. Install floor drains beneath all cleanouts.

Coordinate the location of all storm and sanitary cleanouts with Authority maintenance prior to installing any piping.

#### 2.2.A.8 Miscellaneous Fire Protection Requirements

The Authority's insurance carrier, GE Global Asset Protection Services (GE GAP), inspects the terminal complex on an annual basis and occasionally issues recommendations for remedial action regarding existing facilities. In addition, GE GAP reviews the design documents for all new projects and occasionally specifies adjustments in design criteria (requirements above

the code minimum) to further reduce potential risk. All documentation for new and/or renovation projects must receive GE GAP approval before they are issued for bidding and construction.

Current GE GAP requirements specify 0.12 gpm per square foot density and 100 gpm hose allowance over the hydraulically most remote 3000 square feet for office areas (Light Hazard); 0.17 gpm per square foot density and 250 gpm hose allowance over the hydraulically most remote 3000 square feet for most other areas (Ordinary Hazard Group 1); 0.22 gpm per square foot density and 250 gpm hose allowance over the hydraulically most remote 3000 square feet for baggage handling areas (Ordinary Hazard Group 2). Verify current requirements.

A standpipe system will be an automatic wet system, class 1, 100 psi residual pressure at the most remote hose connection.

All fire sprinkler valves will be located in accessible areas. Access must be possible without a stepladder. If the valves must be concealed, appropriately sized access panels must be provided to allow inspection and/or servicing.

Fire sprinkler zone drain lines will be located at non-traffic locations and will terminate at a floor drain.

Utilized only UL-Listed hot-dipped galvanized hangers and threaded rods to support sprinkler system components in non-conditioned spaces such as: tug tunnels, bag make up areas, shuttle maintenance areas, and sheltered areas (exterior, but under cover.)

Utilize only UL Listed pipes and fittings for wet pipe and dry pipe systems. Pipe and fittings in non-conditioned spaces such as: tug tunnels, bag make up areas, shuttle maintenance area, sheltered areas (exterior, but under cover.) will be factory hot dipped galvanized.

All fire protection equipment and devices will be UL Listed and FM approved.

The designer will carefully consider the potential impact of an accidental discharge or leak from a wet pipe system in rooms housing significant electrical equipment or electronic systems. Increased fire separation provisions may eliminate the sprinkler requirement or negate the need for a dry pipe or pre-action system.

#### 2.2.A.9 Miscellaneous Mechanical Requirements

Provide air conditioning for all mechanical equipment rooms, electrical distribution rooms, systems rooms, the sound rooms.

Install large mechanical system components (chillers, pumps, etc.) on isolated sections of floor slab to reduce vibration transmission throughout the structure.

Provide access panels when it is necessary to conceal a valve, damper, or other device that may require service or adjustment. Generally, it is preferred to locate such devices in mechanical equipment rooms, janitor closets, or plumbing chases. If an access panel cannot be avoided, coordinate location with the Architect.

Air handling unit condensate will drain to the storm sewer system. Chillers will be painted.

Specify a three-to-five year full service extended warranty on any new chillers in addition to a renewable maintenance contract. The warranty documents will list the monthly cost to the Owner for term of the warranty.

Provide sensors to monitor condenser water conductivity and pH, and interface with BCS (METASYS).

Provide vibration isolators on pipe hangers for the preconditioned air system (glycol) piping.

Cooling tower water piping and flange connections exposed to water spray should be constructed of PVC or coated steel.

Provide isolation valves in main glycol piping loop and branch line connections to main header.

All air handling unit equipment condensate drains will be piped to the nearest storm drain line. All air handling unit equipment on large scale "green field" projects, install a condensate collection system to recycle condensate "waste" as make up to replace evaporated condenser water. See system installed at Airside C.

#### 2.2.A.10 Miscellaneous Power Requirements

No exposed conduit will be allowed in janitor closets beneath 8 feet above the floor.

All electrical distribution rooms will be air-conditioned.

Provide GFI (ground fault interruption) at vanities and between lavatories; an outlet must be adjacent to each lavatory.

Install gray 20 amp/120 volt hospital-grade outlets in carpeted areas (100 feet maximum spacing) for carpet cleaning equipment.

Provide power to irrigation system components such as pumps, controllers, and solenoid valves.

Provide power to all parking gates and electrical sliding gates.

Provide power stubups for FIDS system.

Extend normal and emergency power to subpanels in each tenant area.

Provide power source for low voltage 24VDC valves or lavatories, urinals, and water closets. Connect no more than three sensors to each transformer.

Rough-in empty conduit for an intercom system at each tenant's access-controlled security door. Rough-in power to master station location and rough-in system conduit between master station and substation. Typically, the substation will be located on the non-secured side of the access-controlled door hardware for the system will be provided by the tenant).

Rough-in empty systems conduit (for an emergency call system) to a location 1 foot, 4 inches off the floor, between the watercloset and the lavatory in all companion toilets. Extend conduit to near systems room to allow interface with a future master station that may be installed in the security office or the Communications Center.

Provide separate electrical meters, located in satellite electrical rooms, for each tenant space.

Provide emergency power to the waterproof duplex outlets in the elevator and escalator pits.

Provide GFI receptacles in the elevator machine rooms and central plant spaces.

Construction documents will outline all work to be performed. Drawings will show new branch or feeder circuits and identify panel and breaker numbers where originating, size of conduit, size of wire, number of conductors and full load current.

Provide a complete riser diagram if any electrical panels are added. (Having an accurate and complete riser diagram is a necessary tool to support the ongoing maintenance operation as well as provide for future development of the power network.)

Office Design: Provide a clean power receptacle in addition to a normal power outlet at each computer network data outlet. Provide separate transformer, dedicated panel and surge suppression when practical.

#### 2.2.A.11 Miscellaneous Lighting Requirements

All HID downlights will be specified to have a protective glass lens to prevent hot glass from falling in the event of a lamp explosion.

Lighting at all exit stairs will be on emergency power.

Avoid using “shear” light along the walls; it accentuates all imperfections.

Do not install light fixtures (or speakers) above areas inaccessible to a lift device. Lower height construction such as bar/food service and preparation areas, planters, and escalators and stairs can make lamp maintenance impossible.

Provide appropriate lighting to enable nighttime servicing of the cooling tower.

Do not provide switches for toilet room lighting. They are always turned on. The only control is the breaker at the panel.

Provide emergency power to the light fixture in the elevator and escalator pits.

Minimize the use of fluorescent light fixtures. Lamp cost is high and replacement frequency is often.

#### 2.2.A.12 Miscellaneous Systems Requirements

Provide raceways and conductors to monitor and control all elevators from the Communications Center.

The fire alarm system will be the presignal system operated through the Communications Center.

Provide data stubups for FIDS system.

Provide data raceway system and stubups for FIDS system.

Route systems cable tray (data, phone, fire alarm, CCTV, and so forth) to each tenant space.

Provide Gaitronic 280 series telephone in all elevator cabs.

Provide heat detectors in elevator pits.

Provide fire alarm speaker "strobe" devices in all enclosed rooms.

System vendors will provide source codes to allow local software adjustments. Systems include access control, fire alarm, and building management.

Provide fire alarm system annunciator in the fire control room (off the truck court) and in the security office. The system will also provide alarm notification to the Comm. Center in the Service Building.

When possible, expand existing fire alarm and building control systems instead of introducing new systems. Simplex and Johnson Controls are the manufacturers of the existing systems.

## 2.2.B Airside Terminals and Truck Courts

### 2.2.B.1 General Planning Criteria

#### 2.2.B.1.1 Building Envelope Limitations

Provide raceways and conductors to monitor and control all elevators from the Communications Center.

The fire alarm system will be the presignal system operated through the Communications Center.

Provide data stubups for FIDS system.

Provide data raceway system and stubups for FIDS system.

Route systems cable tray (data, phone, fire alarm, CCTV, and so forth) to each tenant space.

Provide Gaitronic 280 series telephone in all elevator cabs.

Provide heat detectors in elevator pits.

Provide fire alarm speaker "strobe" devices in all enclosed rooms.

System vendors will provide source codes to allow local software adjustments. Systems include access control, fire alarm, and building management.

Provide fire alarm system annunciator in the fire control room (off the truck court) and in the security office. The system will also provide alarm notification to the Comm. Center in the Service Building.

When possible, expand existing fire alarm and building control systems instead of introducing new systems. Simplex and Johnson Controls are the manufacturers of the existing systems.

#### 2.2.B.1.2 Shuttle System Design Issues

Provide a 2° angular splay from station centerline for the shuttle station tunnels. The widened exit lobby "throat" allows for better queuing distribution at all entry doors along the boarding area. The minimum lobby width dimension should be 27' - 0".

When designing the tunnel envelope, provide emergency egress doors for any possible vehicle stop location. Misalignment of doors is extremely rare, but all scenarios of misalignment must be planned for, including the worst case of striking and collapsing the buffer. Typically, the emergency egress doors have been concealed by the panel systems between the doors. The existing airside buildings present various approaches to the detailing of these doors.

The maintenance area for the shuttle system is typically constructed at the airside end of the system. The area required for a typical maintenance area is approximately 9,000 square feet. This space includes:

AGT Switchgear	850 SF
UPS Room	160 SF
ATC (automatic train control)	160 SF
Parts storage	1100 SF
Toilet/lockers	64 SF
Maintenance area	6666 SF
(Includes two elevated work platforms 20' x 95')	

These areas are for reference only. Consult with the system manufacturer/maintenance contractor for confirmation or current needs.

With the current Bombardier C-100 car system, the running surface (where the vehicle tires roll) is 3' - 6" below the lobby floor and vehicle floor level. The maintenance platform is 5' - 0" below the running surface and in Airside A the maintenance area is 8' - 4" below the work platform. The elevation difference between the maintenance platform and the maintenance area floor varies from airside to airside. With only 8' - 6" from the lobby floor to the maintenance platform, headroom for the mechanic becomes an issue. As a result, the lobby floor structure cantilevers approximately 5' - 0" on each side thus eliminating deep edge beams. (At Airside A the slab thickness is 10", which allows approximately 7' - 8" of headroom.)

The airside end of the system has also been constructed with wash platforms to allow regular cleaning of the vehicles. At Airsides F, A, E, and C, the 50' platform cantilevers from the outside face the guideway structure. The platform is approximately 5' - 0" wide and is constructed with a metal grating walking surface and enclosed by a perimeter guardrail. Each platform is equipped with a hose bibb and a power outlet to allow the use of a pressure washer. The platform is connected by ships ladder to the interior maintenance platform.

#### 2.2.B.1.3 Special Access Provisions

At Airside A, E, and C three distinct features were included to accommodate the movement of large items in or out of the building.

Near the loading dock, a 10,000 lb. capacity elevator was provided with an 8' x 10'(±) platform and a 6' wide door.

In addition, double wide exit doors have been provided at each airside onto the emergency walkway of the shuttle system to allow the movement of hydraulic boom or scissors lifts to and from the airside and the landside terminal.

On the apron side of the Airside A, a pair of exit doors and an exit stair was detailed to facilitate the movement of large furniture, equipment, or landscape features. The exit doors are equipped with a removable center mullion and the stair landing is detailed to allow the removal of a portion of the guardrail.

At Airside E, a removable section of curtain wall was detailed, without a concrete curb, into the east wall near Gate 75, just south of the outdoor patio.

#### 2.2.B.1.4 Passenger Loading Bridges

The standard passenger loading bridge configuration utilized at this airport is an apron drive unit. Jetway units are in place at Airsides C, D, E, and F. Airside A has Stearns units throughout, with the exception of Gate 16 which is a Jetway unit. Bridges are manufactured in two tunnel and three tunnel configuration depending on the operational needs of the particular gate.

With the closure of Airside D, all airside are now “second generation” airside which have 400Hz power systems and pre-conditioned air systems on all loading bridges. The 400Hz power system consists of a power converter (that hangs beneath the loading bridge tunnel) that converts the standard 48 or 3-phase 60Hz AC power to 90KVA, 200/115V, 400Hz, 3-phase AC power. The pre-conditioned air system consists of a series of air handling units (hung beneath the cab of the loading bridge) with flexible duct connecting to the aircraft utilizing a glycol-based refrigerant system that is processed within the building through a system of chillers, pumps, and ice storage tanks.

In selecting a bridge configuration, the designer must analyze the relationship of aircraft threshold heights, ramp slope, rotunda height, and bridge length to meet the loading door. Bridge floor slope maximums will not exceed 8.33% or 12 to 1.

In analyzing bridge slope, avoid operations within five feet of full extension or five feet of full retraction. Within these limits, the bridges typically operate at half speed.

With many airlines downsizing their fleets to regional jets, they may very soon be a need to reconfigure a number of our current loading bridges to allow them to “stoop” to a lower to a 7'-2” threshold height (M0-80). Several regional jets require the bridge to lower to a 5'-0” threshold height. Rework kits are currently available from several sources.

In developing the apron layout, avoid placing manholes or fuel hydrant pits within expected operating zones for the loading bridge.

Maintain adequate clearance between bridge tunnels and fixed items such as columns and apron lighting poles.

Locate hurricane tie down positions with the bridge in a fully retracted condition as tight to the face of the building as possible. The tie down receptacles will not project above the apron surface and they will not present a tripping hazard.

An appropriate raceway system will be installed in the loading bridge to allow the installation of a telephone at the operator's console.

An appropriate raceway system will be installed in the loading bridge to allow the installation of an illuminated gate identification sign on the aircraft approach side of the cab. (See Airside A and E bridges.)

#### 2.2.B.1.5 Specialized Storage Areas

Provide a storage space for the Maintenance Department to high lift unit. Provide appropriate doors and power outlet to recharge batteries. Doors throughout the facility should be sized to allow necessary movement. Doors to the AGT system emergency walkway will be sized to accommodate the lift.

Provide a storage space for the interior plant maintenance cart. Provide appropriate doors and power outlet to recharge batteries.

Wheelchair storage spaces will be provided near all holdroom areas.

#### 2.2.B.1.6 Holdroom Layout

- In recent years, security concerns have prompted many airlines to relocate their check-in counter/backwall" packages" to a location very near the exterior concourse wall directly adjacent to the loading bridge door. With the closure of the gap behind the backwall, the possibility of an unticketed passenger sneaking onto a flight is significantly reduced.

The close proximity of the check-in counter to the loading bridge has allowed many airlines to reduce the number of personnel required to service a boarding operation. An agent at the counter can now oversee the door in the event that the podium or pass reader agent is required to assist a special needs passenger down the loading bridge.

Orient the check-in counter and backwall at angle (60 ±) facing toward the passengers as they approach the area from the shuttle lobby. The angled orientation increases the visibility of the gate numeral on the top of the backwall.

“Quick-turnaround” airlines such as Southwest require the creation of distinct deplaning and enplaning aisles. The deplaning aisle is usually a well-defined straight “chute” that directs the passenger out into the wider concourse walkway. With Southwest, the boarding queues are separated into four groups; preboards, and the A, B, and C groups. These groups must be separated from the deplaning aisles.

## 2.2.B.2 Equipment/Furnishings

### 2.2.B.2.1 Holdroom Seating

Holdrooms at Airside A, E, F, and C are all furnished with Herman Miller Eames Tandem Sling seating units. These seating units are also used throughout the Landside Terminal.

The tandem seating groupings are assembled in either single gang or back to back configurations with three to ten seat long groupings. Groupings that are too long prove to be difficult to move to allow carpet cleaning or overhead maintenance or housekeeping work.

### 2.2.B.2.2 Airside Check-in Counters (Airsides A and D)

With the development of Airside A, a prototype check-in counter shell was developed. The shell consists of two stainless steel clad end pylons which support a front-projecting transaction surface/cowling fabricated from solid surface material. The front panel consists of two solid surface panels set on a stainless steel-clad backpanel.

The top of the cowling is routed to accept a recessed signage panel containing required FAA notices.

As with ticket counters, an airline specific insert cabinet has been fabricated to accommodate the specific functional needs of their check-in operation. Utility interfaces include: emergency power, telephone, PA system, and data lines (connected to airline's network). Airline standard check-in counters were utilized by Delta and United at Airside E and by Southwest at Airside C.

### 2.2.B.2.3 Airside Back Wall Units (Airsides A and D)

The back wall unit somewhat mimics the detailing of the check-in counter. Stainless steel clad rounded ends and corners surround a plastic laminate wall and storage cabinet.

Storage modules are provided in the lower portion of the front area and full height in two compartments on the back.

The upper portion of the front is allocated for airline signage and flight information displays (gate number, flight number, destination, and departure time).

A fire extinguisher cabinet and a waste receptacle are located on the backsides of the unit.

A sign box is mounted on the top of the storage unit and includes an illuminated gate number sign and a clock on the front and gate number signs on each side. Utility interfaces include: emergency power and data lines (connected to airline's network).

Airline standard back walls were utilized by Delta and United at Airside E and by Southwest at Airside C.

#### 2.2.B.2.4 Airside Gate Podiums (Airsides A and D)

Typically, the airlines have established a final boarding pass checkpoint at the doorway to the lading bridge. These checkpoints vary in configuration with each airline. Some have a podium component with both a computer terminal and an electronic boarding pass scanner; another scanning console; a third may utilize an airport standard podium with an attached proprietary electronic scanning module; and smaller airline may simply have a podium from which the gate agent checks off a paper boarding pass.

#### 2.2.B.3 Conveying Systems

#### 2.2.B.4 Miscellaneous Structural Considerations

At security screening areas, provide adequate loading bearing capacity to support the latest generation of X-ray machines.

During the design of floor systems, consider weights and load distribution of the high lift equipment that will be utilized during construction as well as during the ongoing maintenance operations throughout the life of the structure.

Consult early with the Authority staff and tenant design professionals to establish special loading requirements for planters, aquariums, and any other concentrated load elements that may be associated with a concession buildout (i.e., signage pylons or "umbrella" canopies).

Consult early with signage and FIDS system designers to establish locations of ceiling/roof structure supported elements. The designer will

survey other similar terminal areas to develop a sense of the typical signage locations.

Provide 2" floor depression for tile placement at all toilet room areas.

With the construction of baggage sortation facilities at the airside, elevated floor slab design should address the extensive vibration introduced into the structure by the conveyors and pushers suspended beneath.

#### 2.2.B.5 Miscellaneous Plumbing Requirements

At Airside buildings, provide 1½-inch water stubouts at the building wall for potable water cabinets (a tenant provided item). Potable water cabinets are generally located on the pilot's right side of the aircraft parking position.

#### 2.2.B.6 Miscellaneous Mechanical Requirements

Provide an aboveground fuel tank for the emergency generator. Locate in close proximity of truck court. Verify tank truck accessibility and path for filler hose. The fuel tank construction and installation will comply with all NFPA, EPA, and DEP regulations.

Consult NFPA 415 for height restrictions for exhaust outlets or air intakes located in walls adjacent to the apron/aircraft parking areas.

#### 2.2.B.7 Miscellaneous Power Requirements

Provide disconnects/breakers for the pre-conditioned air system (PCA), the 400 Hz system, and the loading bridge at the building wall beneath the bridge's rotunda.

Provide electric meters on the service to the loading bridges, including the PCA air handler and the 400 Hz equipment. Locate meters in the satellite electrical rooms.

Provide emergency power to all check-in counters, backwalls, and gate podium scanners.

Provide emergency power for the AGT system control system.

Provide appropriate conduit and junction box rough-in to accommodate the power/phone/PA/data systems that serve subsequent bid packages, such as millwork (check-in counters, back wall cabinets, podiums, phone kiosks), and loading bridges.

Provide shunt trips for building and AGT power systems. Provide signage in each switchgear room with instructions indicating how to de-energize both power systems.

Provide electrical rough-in at the transom of the loading bridge door to accommodate the gate identification sign and a future digital flight information signage system.

Provide power rough-in for a future aircraft guide/approach system at each gate position. Locate junction box at 14 (fourteen) to 16 (sixteen) feet above apron elevation at the intersection point of the apron lead-in line and the building wall. Confirm exact placement of rough-in with manufacturer of equipment.

Provide power rough-in for security screening equipment (X-ray machines, magnetometers, etc.) Confirm detailed electrical characteristics for all equipment. At Airside E, it was discovered that all magnetometers must be connected to the same electrical phase in order to operate without electrical interference problems.

Extend power distribution panels to mezzanine levels to accommodate the future development of offices or airline lounge space.

Emergency power requirements: Typically, the following components require emergency power to maintain the basic operational capabilities during a power outage.

- operational lighting for all public spaces
- toilet room lighting
- soffit lighting above exterior stairs
- lighting for interior stairs
- signage lighting
- apron lighting
- truck court lighting
- gate operators
- elevators (provide capacity for only a percentage of the unit, which is switchable to any selected unit)
- passenger loading bridges (provide capacity for only a percentage of the unit, this is switchable to any selected unit)
- sewage lift stations
- jockey pump
- security equipment - magnetometers and X-ray machines
- automatic doors
- turnstiles
- blast fence lights
- generator fuel pump and battery charger
- coolers and freezers (tenant facilities)

- irrigation controllers
- U.P.S. systems for various computer controlled systems
- toilet room devices - electronic flush valves and lavatory faucets
- check-in counters and gate podiums
- telephone kiosks
- sound and fire control room receptacles
- systems equipment - access control and CCTV
- FIDS monitors and EVIDS information boards

Provide power rough-in for potable water cabinets (the unit is generally equipped with a motorized hose reel and a duplex outlet.)

#### 2.2.B.8 Miscellaneous Lighting Requirements

Design apron lighting with light sources aimed at the cargo loading side of the aircraft (pilot's right side).

Apron lighting will be high pressure sodium, with double arc tubes, quartz restrike and remote ballasts. Do not provide any dimming capability; it should either be "fully on" or "completely off."

Consider supplemental task-oriented lighting at ticket check-in counters and podiums. Carefully consider the impact of glare on computer screens.

Prepare a point-by-point photometric analysis of apron lighting prior to finalizing design.

### 2.2 Building Objectives - Planning Criteria (Continued)

#### 2.2.B Airside Terminals and Truck Courts (Continued)

##### 2.2.B.9 Miscellaneous Systems Requirements

Provide rough-ins for public address (microphone station), data and phone at all check-in counters and gate podiums.

Design PA system with zones at each gate area. Do not provide local amplifiers that can be adjusted by gate agents. Locate all amplifiers in a common air-conditioned sound room.

Provide conduit/junction box for telephone installation on a loading bridge.

Provide separate cable trays or conduit for power and systems under and between each check-in counter.

Provide interface with terminal master clock system. Extend to all check-in counters and other clock locations.

Provide data conduit from the check-in counter to the transom of the loading bridge door to accommodate a future digital flight information signage system.

Provide raceways, conductors, and push, buttons for the passenger screening area phone and "trouble" alarm systems. The alarm will be interfaced with police department dispatch computer system.

Develop decentralized "satellite" system rooms to provide localized connection/distribution points for phone, access control, fire alarm, data, and so forth. Locate systems room within the 100 meter maximum copper cable length.

Locate fire annunciator panels in the fire control room (accessible directly from the truck court) and the security office.

Extend the conduit or cable trays for phone, data, and other systems to the mezzanine level to accommodate the future development of offices or airline lounge space.

Provide appropriate raceways, conductors, and the necessary support equipment to provide monitoring at the Comm. Center of the following equipment and/or systems: fire alarm (typically Simplex); building management system (typically Johnson Control Metasys), elevator/escalator (typically Schindler), and access control. A trouble alarm will also be installed at each security screening area that is connected to the police department dispatch computer.

Require a five-year warranty on the public address system.

#### 2.2.B.10 Building System Rough-in Provisions for Tenant Provided Equipment

Provide electrical junction boxes for aircraft parking "guide/approach system." Locate at approximate boarding level beam line at the projected intersection of parking lead-in lines.

Provide concealed empty conduits from the base of apron lighting poles to the apron level ceiling space to accommodate ground radio antennas that may be required by tenant airlines. Detail lighting poles to allow attachment points for these antennas. Confirm conductor size for antenna. Many airlines specify cabling that requires a 2" diameter conduit system.

Provide electrical junction boxes for hose reel power at locations appropriate for potable water cabinets. Typically, cabinets are placed to the pilot's right side of the projection of the lead-in line extended to the building wall. Water source will be a valved 1 ½" line.

Provide electrical junction boxes for electric water coolers. Coordinate placement with a valved water line and sanitary drain.

Provide separate signal and power conduits to the locations planned for communication antennas and satellite dishes.

#### 2.2.B.11 Truck Court Elements

An airside terminal truck court typically includes the following components:

##### 2.2.B.11.1 A Guardhouse Placed Between Gate-Controlled Entry and Exit Roadways

Truck court entry and exit gates are controlled from the guardhouse. All vehicles entering the truck court must display proper identification. A guardhouse will be located adjacent to the service road and between the entry and exit gates. The guardhouse will have a clear view of AOA entry gates that are nearby. The guardhouse will be equipped with 120 volt power, an air conditioning/heating unit, telephone service, and be interfaced with the access control system to allow gate control.

##### 2.2.B.11.2 AOA Entrance Gate(s)

The AOA gates will be electrically operated horizontal sliding cantilevered gates with sensitive edges that reverse the operation in the event of contact with a vehicle. The gate operator is to be interfaced with the access control system. Valid security identification must be presented to a card reader when passing through in either direction. Typically, an entry and an exit gate are provided at each AOA entry point. The drive lanes are separated by a raised curb. On the curb are two card readers and numerous pipe bollards to protect the equipment.

Inductive loop detectors are placed in both drive lanes to ensure the vehicles pass through the gates in a prescribed sequence. The loops on the existing side, of either approach direction, serve to monitor the position of the vehicle during the closing cycle of the gate operation.

By requiring the vehicle to maintain a nearby parking position until the gate closes, the vehicle operator becomes responsible for supervising the gate operation during both the opening and closing cycles. This operation also prevents two vehicles from passing through on a single access card swipe (piggybacking).

#### 2.2.B.11.3 Transformer Enclosure (Building and Shuttle System Equipment)

At Airside A, a transformer enclosure was constructed adjacent to compactor enclosure. The concrete and masonry structure has a removable metal grating top that screens the electrical gear from view from above. The yard area enclosed is topped with course stone except at the concrete equipment pads. An underground drainage system is required to relieve any significant water accumulation. At Airside C, the generator building and transformer yard were combined into single enclosure. At Airside E, the generator building, the transformer yard the cooling tower and the compactor/dumpster enclosure were combined into a single concrete and masonry structure.

#### 2.2.B.11.4 Trash Compactor Enclosure

A trash compactor is generally placed in a concrete/masonry enclosure. The compactor is generally integral with a 30 cubic yard trash container. When the compactor/container is removed for dumping, the compactor must be disconnected from a stationary hydraulic pump unit. The combined compactor/container assembly reduces the spillage that may result from a two component installation.

Electrical service will be in accordance with the container/compactor manufacturer's specifications.

The concrete slab should slope outward toward a trench drain and should be poured with steel guide channels to serve as the bearing surface for the container rollers as it is being removed or reset in place. The interior of the concrete enclosure should be constructed of poured-in-place concrete.

A pressure wash unit should be installed to allow periodic clean ups.

#### 2.2.B.11.5 Loading Dock

At an airside, a loading dock will be constructed with minimum two berth width, 30'-0"±. The dock should be constructed with a minimum 10'-0" clear overhang to allow unloading during rain. The dock height is typically 4'-0".

#### 2.2.B.11.6 Access Doors to Shuttle Maintenance Spaces

At the airside, exterior access doors are required for the following maintenance area spaces:

AGT Maintenance Space	- man door and overhead door
AGT Switchgear Room	- man door and overhead door
UPS Room	- overhead door
ATC Room	- man door

(See the Airside E and C construction documents for most recent configurations of shuttle maintenance areas)

#### 2.2.B.11.7 Access Doors to Maintenance Areas and Central Plant

At the airside, exterior access doors are required for the following spaces:

Mechanical Equipment Room	double man door
Electrical Room	double man door
Fire Pump Room	double man door
Central Plant	man door and overhead door
Communications Room	man door

#### 2.2.B.11.8 Access to Fire Control Room

At Airsides A, E and C, the fire control room is located at or adjacent to the loading dock.

#### 2.2.B.11.9 Emergency Generator Enclosure and Cooling Tower

At Airside A and E, the cooling tower and the emergency generators are housed in adjacent concrete and masonry structures. The emergency generator area includes the generator unit, with control console, and an above ground fuel tank. The designer will consider the normal length of fueling hose and available tanker truck parking positions when siting this enclosure. All exhaust pipe exposed to view will be fabricated from stainless steel. Consult with DEP for special fuel facility regulations.

#### 2.2.B.11.10 Flight Crew Loading/Unloading Area (Hotel Courtesy Vans)

At Airsides A, E, and C, flight crew entrances routes have been created to allow for non-Tampa badged airline personnel to enter the building and gain access to the Boarding Level passenger screening area. (Consult construction documents for Airsides A, E, or C.)

#### 2.2.B.11.11 Ramp to Loading Dock

At Airsides A, E, and C, a ramp has been constructed to connect the loading dock to the truck court driveway to facilitate trash removal, handicapped access, and maintenance access.

#### 2.2.B.11.12 Truck Court Lighting

#### 2.2.B.11.13 Staff Parking Area

Every attempt should be made to maximize the amount of staff parking spaces in the truck court area. At least two spaces will be provided for Authority maintenance vehicles adjacent to the Central Plant overhead door.

#### 2.2.B.11.14 Access-Controlled Pedestrian Turnstile

Pedestrian access to the AOA area is provided from the truck court via an electronic turnstile within the fence line. The turnstile operator is actuated by an airport employee ID/proximity card badge.

#### 2.2.B.11.15 Maneuvering and Turn Around Area in Truck Court

Typical vehicles accessing the truck court can include large semi-trailer units, large roll-off container trucks (to haul the 30 cubic yard trash container/compactor unit), fuel trucks, and various fire department apparatus. Adequate maneuvering space must be provided for all vehicles.

#### 2.2.B.11.16 Miscellaneous Site Utility Elements:

Double detector check valve for fire and domestic water service (with landscape screening); lift station for sanitary sewer (if required); irrigation system valves and controllers; manholes; fire department valves/standpipe connections

Provide water and power sources for irrigation system. Locate controllers and all solenoid valves in boxes below grade. (Investigate the possibility of utilizing nearby retention pond water for irrigation.)

Locate fire department connection (FDC) with 1000 GPM flow rate, maximum 6' from curb in an appropriate and accessible location. Verify position with the Fire Department.

Utilize landscaping elements to screen truck court from the service road and/or the shuttle system vehicles.

### **Section 3 – Building Sections and Components**

#### 3.1 Division 1 – General Requirements - Reserved

#### 3.2 Division 2 – Site work – Reserved

##### 3.2.A Section 02221 – Building Decommissioning and Demolition

Prior to the demolition of a building or structure, all hazardous waste and materials must be disposed of in accordance with all applicable federal, state, and local regulations including but not limited to OSHA, EPA, DOT, FDEP, and EPC regulations. The waste disposal transporters must be FDEP approved and provide a current State of Florida Hazardous Waste Transporter Status Form (DEP Form 62-730.900(5)(d) showing Transporter EPA ID Number. Copies of all waste disposal manifests must be provided to the Authority at the completion of the waste disposal task.

Asbestos survey, abatement, and disposal activities must be conducted in compliance with all applicable federal, state, and local regulations including but not limited to OSHA, EPA, FDEP HRS, and EPC regulations. Air quality monitoring (personal or ambient) during the asbestos abatement activities must be conducted by the contractor independently of other entities providing oversight.

##### Applicable Codes and Reference Standards

Applicable regulations include but are not limited to:

29 CFR 1910 Sections 2, 134, 145

29 CRR171 and 172

Chapter 99-469.001 99-469.015 of the Florida Statutes

40 CFR 61, Subpart M, and Section 61.145

#### 3.3 Division 3 - Concrete

##### 3.3.A Section 03200 - Concrete Reinforcement

In architectural concrete, only stainless steel tie wire will be used.

##### 3.3.B Section 03300 - Cast-in-Place Concrete

The typical concrete for airport construction will have standard gray cement and normal weight limestone aggregate in accordance with ANSI/ASTM C 33.

All architectural concrete surfaces will be finished with a water-repellant.

The typical concrete floor slab finish, for a floor to receive VCT or carpet, will be steel-troweled with a liquid membrane forming, curing, and sealing compound.

The typical finish for a floor slab that is to be left exposed will be a "lightly broomed" finish with a liquid membrane forming, curing, and sealing compound.

Typically, slab hardener products are not used.

Typically, all slabs will be installed over compacted fill and a vapor retarder membrane (normally asphalt impregnated felts). At Airsides C and E, a heavy Stego-Wrap barrier (Stego Industries, (877/464-7834) was installed beneath the ground floor slab to prevent the upward flow of fuel vapors that exist in the building subgrade. This barrier has taped seams and is detailed to fit tightly around all vertical slab penetrations.

### 3.4 Division 4 - Masonry

#### 3.4.A Section 04200 - Unit Masonry

Glazed brick for Landside Terminal renovations will be as follows:

Red face brick: "TIA - Red Glazed" by Belden Brick Co.

Blue face brick: "WG-90-3368" by Glen-Gery Corp.

White face brick: custom beige" to match existing by Endicott Clay Products, Co.

Sources: Clay paving bricks for Bag Claim and Ticketing Level paving bands:

Precast concrete pavers: 2'-0" x 2'-0" x 1-1/4" for Bag Claim, Ticketing and Plaza Level areas.

### 3.5 Division 5 – Metals

#### 3.5.A Section 05511 - Metal Stairs

Exterior stairs and ladders will be left unpainted with a galvanized finish. Large assemblies will be detailed using "bolt-together" components or sub-assemblies. The weakest point in the integrity of a galvanized coating is in the area of a field weld that has only a thin, sprayed-on cold-galvanizing coating. Extensive preassembly by welding, before galvanizing, can be counter productive because the high heat associated with the galvanizing process will warp a competently prepared assembly to the point that it may not be usable. The designer will verify the limits on component or subassembly size dictated by capabilities of local processors

When fielding-welding is necessary, cold-galvanizing must be used to complete the corrosion protection. Careful research and sample procurement are necessary to find a matching cold-applied product.

Avoid products that tend to be a flat gray (either too light or too dark) without the “metallic” look.

### 3.6 Division 6 – Wood and Plastics

#### 3.6.A Section 06100 - Rough Carpentry

In recent years, it has been discovered that the structural integrity of fire-treated wood framing and plywood can deteriorate significantly when exposed to the radiant heat of light fixtures (including fluorescents). Research the products carefully before specifying or using fire-treated wood. Do not use in a loadbearing condition. Backing boards for telephone terminal boards are acceptable. The painting of backing boards will be performed outdoors away from conditioned spaces.

### 3.7 Division 7 – Thermal and Moisture Protection

#### 3.7.A Section 07190 - Water Repellants

Exterior exposed concrete surfaces will be typically coated with water repellent.

#### 3.7.B Section 07411 – Metal Roof Panels

Six aluminum standing roofing systems have been installed at the airport. The Delta Hangar and Airside F are built with the Merchant and Evans, “Zip-Rib” system; the U.S. Airways Hangar (steel) and Airside A are built with a Centria(formerly H.H. Robertson/Smith Steelite) SRS-3 system; and Airside E and C and the Airside A baggage sortation building are built with a BemoUSA Corp. 305 system. All systems are field-formed from Kynar-coated aluminum coil stock, 0.40-inch thick. Panel lengths on the hangars approach 125 feet; Airside E has panels in excess of 250 feet long; and Airside C has panels exceeding 370 feet in length. Special detailing considerations are required to accommodate the thermal expansion of the very long roof panels. All systems have nominal 3-inch-high standing seams that are sealed with sealant and an electric sealing tool. All systems use a stainless steel clip system which attaches to a heavy gauge metal purlin system.

The curved panels on Airside A and F were formed in the field by running the panels through a second roll-forming machine to create the desired radius. Gutters for the standing seam roofs are formed from 18 or 16 gauge stainless steel that is fully welded and water tested.

Gutter expansion joints are typically spaced 30 to 40 feet on center. Downspout drops are formed from the same gauge stainless steel (18 or 16), and are welded to the gutter box. Transitions are then made to connect to the building's downspout system (steel or PVC, depending on conditions).

### 3.8 Division 8 – Doors and Windows

#### 3.8.A Section 08110 - Steel Doors and Frames

Do not specify of doors fabricated with vertical galvanized sheet steel channel-shaped sections or interlocking Z-shaped sections. The doors on Airside A exhibit significant spot weld dimples on the face panel at each of these reinforcement members. Care should be taken in considering acceptable manufacturers. Consider requiring a door and frame sample to assess quality of hardware preparations and finish. Galvanize all exterior doors and frames.

On frames with access control hardware, require the inclusion of a tightly sealed mud box, with a flexible conduit connection at each attachment point for electronic hardware. A continuous raceway must be provided from the face of the door from e to a system junction box located near the door. With a definitive conduit route, a new conductor can be re-pulled into the hardware location whenever necessary.

Airside F had significant wiring difficulties because of improperly constructed wiring raceways.

Each exterior door will be equipped with a small permanently affixed sign numbering the door in accordance with the Authority door numbering system. The sign will be placed in the upper hinge side corner of the door.

#### 3.8.B Section 08211 - Flush Wood Doors

Typically, interior wood doors in airport buildings are solid core assemblies with plastic laminate faces.

#### 3.8.C Section 08411 – Aluminum-framed Entrances and Storefronts

Use only “wide-style” sections for aluminum and glass entrance doors. The construction is more durable and the wide face dimension provides enough surface to accommodate all hardware components.

#### 3.8.D Section 08461 – Sliding Automatic Entrance Doors

Fabricate entrance doors and side lights with “wide-style” sections to match manual doors.

Provide a minimum opening width of 5 feet, 0 inches, clear.

Detail assemblies with both inside and outside side light elements. The outside piece will require breakaway hardware to maximize egress width.

The inside fixed panel must be installed so as to protect any unsuspecting individual from the suddenly moving edge of the operable door.

### 3.8.E Section 08710 - Door Hardware

Locks will be Corbin/Ruswin ML 2000 Series (no substitution) with removable core cylinders.

All permanent cores are to be great grand master keyed into existing or Authority approved Ruswin removable cores, H Keyway 6-pin system, in accordance with owner's key control requirements and instructions. Owner is the Authority. Individual door keying requirements are to be established in a meeting with the Contractor, user, architect, Authority, key control staff, Operations and others as deemed appropriate by the Authority. Key bittings will be per Authority requirements and provide upon project completion to the Authority.

Unless otherwise agreed, permanent keys are to be delivered to the Authority key Authority will direct installation and establish key control over the permanent key set. The Authority reserves the right to order and install the cores for any project. If this occurs, the Contractor will install a construction set as directed by the Authority and they will be returned to the Contractor when the final set is installed.

For factory ordered cores, the order must be received by the factory a minimum of 90 calendar days prior to occupation. If delivery is not by space use date, the contractor must provide a construction set with all keys that mimics how the final key set will operate and that set must be available for installation a minimum of 10 calendar days prior to space use or sooner if so directed by the Authority.

Panic devices will be Von Duprin 99 - Series touchbar devices. No exposed vertical rod devices are allowed.

Hinges will be Hager, McKinney, or Stanley. Units installed on exterior doors will be stainless steel. Units installed with door closers will have ball bearings.

Door closers will be Corbin/Ruswin 2200 series. Valve body will be located on the non-public face of the door whenever possible.

Stainless steel kickplates will be provided at all high-traffic doors (push side). Armor plates will be installed at all doors where carts or equipment will be pushed against the door while it is being opened.

Access control: Designers will coordinate door hardware and access control electronic device installation to verify that all operational objectives are met. Refer to Section 16730 for narrative on access control operations.

### 3.9 Division 9 - Finishes

#### 3.9.A Section 09220 - Portland Cement Plaster

Exterior stucco areas will use only zinc alloy or PVC accessories: corner beads, casing beads, control joints, and so forth.

Framing for exterior soffit areas will use "stiff-leg" framing that is engineered for both positive and negative uplift loading.

#### 3.9.B Section 09310 - Ceramic Tile

Floor and wall tile will be 4 inches by 4 inches minimum size (larger sizes are preferred).

Grout will be gray-colored grout, with a maximum joint width of 1/8 inch.

Backing for tile on fixture or "wet" walls will be a glass fiber-reinforced cement board, such as "Durock" or "Wonderboard."

Transitions from ceramic tile to another floor finish (carpet, vinyl composition tiles, and so forth) will use a tapered marble strip that provides an ADA-compliant transition between the varied finish thicknesses.

### 3.10 Division 10 - Specialties

#### 3.10.A Section 10155 - Toilet Compartments

The partition system will be manufactured by the American Sanitary Partition Corporation (no substitution).

The installation will be a ceiling-hung configuration, except at large handicapped stalls, where a full height pilaster may be necessary to achieve proper lateral stability for the compartment front. In Airside A, a removable floor connection was designed to allow periodic disassembly to facilitate a thorough cleaning of the floor in the area of the pilaster footprint.

Doors will be reinforced to prevent racking and twisting.

The panels will be furnished with the manufacturer's standard powder-coated finish.

All hardware will be consistent with the parts inventory maintained by the Authority Maintenance Department.

Accessory and partition installers will coordinate placement of accessories to prevent damaging contact between components.

Coat hooks will not be placed on the inside face of an outward swinging door. At the normal placement height, the hook can become a dangerous projection. Locate on a side wall near the back of the compartment, safely out of the way. In the larger handicapped stall, the hook can be located on the front panel opposite the water closet.

Coordinate wall framing to provide solid wall reinforcement or backing between studs to provide a competent anchoring substrate.

### 3.10.B Section 10265 – Impact-resistant Wall Protection

In public area service corridors and at high traffic corners within the Authority offices, install corner guards to protect the wall. Typical corner guards are SM-20 units (surface-mounted) and FS-20 or 20R units (flush-mounted in gypsum board partitions), by Construction Specialties, Inc. or approved equal. At non-gypsum board partitions (masonry or concrete use 6 gauge stainless steel corner guards, with ½" hemmed edge on 3 ½" wide flanges).

In service areas, where carts or rolling equipment circulate frequently, it is appropriate to install both crash rails and corner guards. At Airsides E and C, dual crash rails were used to protect the walls, one just above the base and another at about 4'-0" above the floor. The crash rails are SCR-64 units by Construction Specialties, Inc., or approved equal. Corner guards are SM-20 units for surface mounted conditions and FS-20 units for flush-mounted conditions, by Construction Specialties, Inc. or approved equal.

### 3.10.C Section 10450 - Pedestrian Control Devices

At AOA pedestrian access points, a full-height turnstile (Model MSTX by Alvarado Manufacturing Company, Inc.) will be used. Controlled access is required in both directions. Allow a maximum 120-degree rotation with each card activation.

Refer to Section 16730 for narrative on access control operations.

### 3.10.D Section 10801 - Toilet Accessories

Toilet accessories will be by Bobrick Washroom Equipment, Inc. (no substitution) typical units are as follows:

B-224: Surface-mounted utility shelf, with mop/broom holders and rag hooks.

B-2621: Surface-mounted paper towel dispenser (typically used only in non-public service areas).

B-274: Toilet tissue dispenser, double roll (typically used only in non-public service areas).

B-290: Mirror with stainless steel angle frame (used above makeup vanities, and in full-height dressing configurations).

B-347: Partition-mounted toilet seat cover and toilet tissue dispenser (for installation between two toilet compartments, without grabbars in a men's restroom).

B-3471: Partition-mounted toilet seat cover and toilet tissue dispenser (for installation between two toilet compartments, one with grabbars, in a men's restroom).

B-3474: Recessed toilet seat cover and toilet tissue dispenser (for installation in a handicapped stall, with grabbars, in a men's restroom).

B-3500: Recessed napkin/tampon vendor, single coin mechanism, 25-cent operation.

B-357: Partition-mounted toilet seat cover dispenser, sanitary napkin disposal, and toilet tissue dispenser (for installation between two toilet compartments without grabbars in a women's restroom).

B-3571: Partition-mounted toilet seat cover dispenser, sanitary napkin disposal, and toilet tissue dispenser (for installation between two toilet compartments, one with grabbars, in a women's restroom).

B-3574: Recessed toilet seat cover dispenser, sanitary napkin disposal and toilet tissue dispenser (for installation in a handicapped stall, with grabbars, in a women's restroom).

B-3644: Recessed waste receptacle for 4-inch wall.

B-3900: Recessed paper towel dispenser and waste receptacle (for 8-inch wall or chase).

B-3944: Recessed paper towel dispenser and waste receptacle (for 4-inch wall).

B-6717: Surface-mounted robe hooks.

B-6806: 1½-inch (38mm) diameter stainless steel grabbars, with snap-flange cover.

In 2004, Bobrick discontinued the production of two multi-purpose soap dispenser/towel dispenser units (Items B-317 and B-330) that had been specified extensively for the larger terminal toilet rooms. As result, a Bradley Corporation product has been selected as a replacement unit: Model 130, a recessed multi purpose towel dispenser/soap dispenser/mirror/shelf unit. As with the Bobrick unit,

the soap dispenser valve must be specified offset to the right to prevent soap from dripping on the faucet spout.

3.11 Division 11 – Equipment - Reserved

3.12 Division 12 – Furnishings - Reserved

3.13 Division 13 – Special Construction

3.13.A Section 13900 - Fire-Suppression System

All exposed sprinkler and standpipe piping will be painted red.

3.14 Division 14 – Conveying Systems

3.14.A Section 14200 - Elevator General Requirements

The controller must provide for future tie-ins to a vertical transportation monitoring system.

Initial maintenance service will include: fully paid, full service maintenance warranty service by skilled, competent employees of the elevator installer for a period of 12 months following the Date of Final Acceptance by the Owner on a daily-surveillance basis. Include repair or replacement of worn or defective parts or components and lubrication, cleaning and adjusting as required for proper elevator operation in conformance with specified requirements. Include 24 hours-per-calendar day, 7 calendar days-per-week emergency callback service. Exclude only repair or replacement due to misuse, abuse, accidents, or neglect caused by persons other than installer's personnel. Installer will have maintenance personnel at Airport property 24 hours-per-calendar day, Monday through Friday, 0600 hours until 1830 hours Saturday, and 0700 hours until 2130 hours Sunday and holidays. This work will not be subcontracted. Only parts and supplies as used in manufacture and installation of the original installation will be provided.

System maintenance service will include: Contractor, at Contractor's own cost, agrees to furnish to Owner an executed Amendment with the current Contractor specified in this Design Criteria under Section 2.2.A.3.9 Maintenance Contracts. This amendment to the existing "Maintenance Contract Elevators, Escalators, and Dumbwaiters, Tampa International Airport" will expand the Scope of Work of the existing contract to include the Work of this Section, " Section 14240 - Hydraulic Passenger Elevator," of the Contract between Owner and Contractor. All Work under this Section will be added, by said Amendment and at no direct cost to the Owner, to the existing "Maintenance Contract Elevators, Escalators, and Dumbwaiters, Tampa International Airport." Said Amendment will be automatically effective on the date of Substantial Completion of the whole Work. All other terms and conditions of the existing "Maintenance Contract Elevators, Escalators, and Dumbwaiters, Tampa International Airport" will remain unchanged.

The design will include TriTronics safety edges.

Doors will be finished in #4 stainless steel.

ADA Compliant elevator telephones, such as the Micro Tech Emergency telephones, will be integral with the car station.

No elevator hoistways will have sump pumps or drains.

The key lock cylinder in the restricted-access keyed switch in the elevator car operation panel will match the Owner's standard.

Cars will have a 1.5" x 4" cutout adjacent to each floor level pushbutton for installation of graphics by the Owner.

Work on existing elevators will include modifications as necessary to meet applicable fire safety code requirements.

All work in existing elevator machine rooms and hoistways will be accomplished with the Elevator Maintenance Contractor mechanic present.

Elevators will not be used for construction purposes even on a temporary basis.

For additional notes, see the general hydraulic elevator specifications on file at the Authority.

#### 3.14.B Section 14215 – Electric Traction Elevators

No traction-type elevators will have sprinkling systems installed in the elevator machinery rooms or hoistways.

For additional notes, see the traction elevator specifications on file at the Authority.

#### 3.14.C Section 14240 - Hydraulic Elevators

The design will include Lifejacket hydraulic elevator safety brakes. For additional notes, see the hydraulic elevator specifications on file at the Authority.

#### 3.14.D Section 14310 - Escalators

See the escalator specifications on file at the Authority.

#### 3.14.E Section 14410 - Dumbwaiters

See the dumbwaiter specifications on file at the Authority.

---

### 3.14.F Section 14600 - Outbound Baggage Conveyors

Conveyors will initially start only by turning on a keyed switch to "on" and depressing a green "Start" button at the conveyor originating point, which will open all associated security doors. Audible and visual alarms will warn operators that a conveyor is about to start.

Conveyors will be secured by turning a keyed switch to "Off," which will immediately stop the sections of conveyor at the respective ticket counter or curbside area and if a ticket counter conveyor, close the conveyor security door. Other sections of the conveyor will be staged to stop as necessary to allow baggage on the conveyor to continue on to the Bag Make-up Area.

Conveyor security doors will have easily removable, secure access panels through walls or other obstructions allowing access for maintenance and repairs.

"Jam Photosensors" will be located at strategic areas along the conveyor system such as upstream from power turns and at periodic lengths not to exceed 50' along straight conveyor sections. Jam sensors will stop all upstream conveyor sections while allowing the downstream conveyor sections to continue to run.

"Jam Reset" buttons will be located at each jam photosensor and be accessible from a catwalk adjacent to the conveyor allowing safe reset by the operator.

"Emergency Stop" buttons will be located at the beginning of the conveyor, at each "jam reset" button, on each control panel and at a distance of no more than 20' apart along each Bag Sort Device. These "E-stops" will stop the entire conveyor system when depressed. Pulling out the E-stop will not restart a conveyor belt; it will start only by depressing the green "Start" button.

Personnel catwalks with safely accessible, permanently installed or pull-down ladders will be installed adjacent to conveyor system motors, gearboxes, photosensors, jam resets, and E-stops.

Conveyors catwalks will be constructed with a vertical clear space of six feet. Lighting and convenience receptacles will be provided and spaced appropriately to allow proper maintenance of the equipment. Conduit, lighting, fire sprinkler lines and heads, plumbing and other building systems will not violate the clear space of the catwalk. Location and construction of each catwalk will be coordinated with and approved by the Maintenance Department prior to installation.

The conveyor control panel located in the Bag Make-up Area will have the ability to start only the Bag Sort Device or Carousel without starting the remainder of the conveyor system. Additionally, it will be possible to turn off the Bag Sort Device or Carousel with the remainder of the system continuing to run.

Conveyor control panels will have a placard with a graphic of the conveyor layout with indicator lights, which illuminate for jam indications or depressed E-stops.

The installing contractor will provide a copy of PLC programming software to the Owner to enable follow-on troubleshooting and repair. Disconnects will be installed at each motor.

Where physically possible, conveyor belts will not merge with any other conveyor prior to reaching the Bag Sort Device.

#### 3.14.G Section 14630 - Sloped-Plate Sorting Carousels - Reserved

#### 3.14.H Section 14650 - Inbound Baggage Conveyors (Flat-Plate)

Transitreads will be normally started from the Bag Make-up side of the belt by depressing a green "Start" button. They may additionally be started by turning a keyed start switch on the Bag Claim side.

All components of security doors will be removable for maintenance.

Transitreads will have emergency-stop buttons located on each side of the transitread on the Bag Claim side and at the Bag Make-up Control Panel, which illuminate when depressed and stop all power to the system, including a security doors. Upon pulling out the E-stop, the security doors will close. Keyed start switches will be located adjacent to each E-stop on the Bag Claim side to restart the system.

Each transitread will have the capability of accepting a remote control cable operating station for use by maintenance personnel.

Each transitread will have an adjustable section to allow for expansion and contraction of the system linkage.

All grease fittings will be connected to a remote manifold allowing greasing of the linkage without the need for disassembly.

#### 3.14.I Section 14800 - Apron-Drive Passenger Loading Bridges

Mirrors will be installed allowing the bridge operator to view the drive wheels from the operator station.

An audible alarm and visual beacon will warn ground personnel that a bridge is energized and about to move.

The auto-leveler will have an audible and visual alarm at the console and under the bridge to alert personnel of a malfunction.

Floodlights will be installed at locations to illuminate the drive wheels and nose wheel of the aircraft.

A cab-floor light will be installed to illuminate the vestibule area between the aircraft and the bridge cab.

Each ramp area between tunnel sections will be equipped with ADA safety handrails.

Bridges will be constructed in accordance with NFPA guidelines for fire-retardant materials.

Side-mounted vertical maintenance ladders accessing the top of the bridge will have a safety cage surrounding the ladder.

If installed, bridge-mounted baggage slides will be of stainless steel construction with bracing mounted to the structural portion of the bridge and not cantilevered solely from the bridge stairs.

### 3.15 Division 15 - Mechanical

#### 3.15.A Section 15030 - Electrical Requirements for Mechanical Equipment

##### 3.15.A.1 Basic Motor Construction (15055)

General: Provide motors for continuous duty conditions in which they will be required to perform (i.e., general purpose, splash proof, explosion proof, standard load, high torque, or any other special type) as required by the equipment motor manufacturer's recommendations. Unless otherwise indicated or required, motors will be open drip-proof.

Motors installed outdoors will be totally enclosed and fan-cooled (TEFC).

Motor enclosures will be as recommended by the equipment manufacturer for the specific application.

All motors will be furnished for starting in accordance with the electric utility company's requirements, and will be compatible with the motor starter and driven load. Motors will not exceed full-rated nameplate load when operated at any point along the driven equipment's characteristic performance curve. The motor service factor will not be used to justify exceeding nameplate amperage.

Unless otherwise indicated, motors of 1/2 horsepower or less, will be single-phase. Motors of 3/4 horsepower and larger, will be three-phase, squirrel-cage induction.

Sound power levels for motors will be no greater than the guidelines as recommended by NEMA, MG 1-12.49. A motor which, in the opinion of the Architect, generates excessive noise within the occupied area of the

building, will be replaced with a quieter operating motor at no additional cost to the Owner.

Motors designed to operate with a variable frequency drive will be approved by the manufacturer of the variable frequency drive equipment, and the manufacturer of the motor for inverter duty to insure quiet and stable continuous operation over the entire speed range.

Verify the circuit voltage and phase being furnished to the motor. All motors will be 1750 rpm, unless noted otherwise. Motors will operate with electrical input voltage variations of plus or minus 1 % of nameplate rating, or frequency variations of plus or minus 5 % of nameplate rating.

Design: Provide NEMA Design B for normal starting torque, with Standard MG1 12.42 Class F insulation, unless noted otherwise, or required by the equipment on which the motor is being used. Motors will be designed for operation in 104 degrees Fahrenheit (40 degrees Celsius), ambient temperature at 1.15 service factor on sine wave power at the base voltage and frequency, and will have all copper windings. Motors will meet or exceed the locked-rotor (starting) and breakdown (maximum) torques for the NEMA rating. Locked rotor current will not exceed six times full-load current. Motor current density and heating characteristics will be such that the motor insulation will not fail if subjected to locked-rotor current for 20 seconds.

Acceptable manufacturers for motors are General Electric, Westinghouse, Baldor Electric Company, Emerson, and Lincoln.

Efficiency: Motors 1 horsepower and larger will be high efficiency design.

### 3.15.A.2 Variable Frequency Drives (For Air Handling Units and Pumps)

Variable Frequency Drive: Specify variable torque Variable Frequency Drives (VFD) variable speed operation where suitable for controlling NEMA Design B motors on continuous duty in variable speed applications. The VFD will be listed by Underwriter's Laboratories and will comply with the latest standards of ANSI, IEEE, and the NEC.

Manufacturer: Refer to paragraph entitled "Manufacturers" in Section 15010. Acceptable manufacturers are as follows:

- a. Asea Brown Boveri (ABB)
- b. Cutler-Hammer, Eaton Corporation
- c. Allen-Bradley

Control Requirements: The following control interfaces will be provided at a terminal strip in the VFD as a minimum to assure control system integrity:

- a. Speed Control Input: A 4-20mA, or 0-5 vdc signal proportional to speed will be input for directly controlling the speed of the VFD when in automatic mode.
- b. Start/Stop Control: The VFD will be capable of being started and stopped remotely by a maintained-contact start/stop relay.
- c. Control Interlock: The VFD will provide an auxiliary control interlock output of 115 VAC whenever the VFD is enabled, to provide interlocking with the control system. The VFD will be provided with a 115 VAC control transformer so that no external 115 VAC power source is required.
- d. Speed Signal Reference: The VFD will furnish a 0-5 VDC, or 4-20mA signal directly proportional to the output frequency of the VFD for remote monitoring of the VFD speed.
- e. Hand-Off-Auto Switch: The VFD will be furnished with a door-mounted Hand-Off-Auto switch to allow switching of the speed control signal from the "Automatic" signal to a manually adjustable digital speed control on the VFD when in the "Hand" position. The VFD will be disabled when in the "Off" position.
- f. VFD Trip Contacts: The VFD will be furnished with a set of Form C (NO/NC) contacts for remote annunciation to the building automation system under Section 15950.
- g. Speed Control: A digital manual speed control will be door-mounted to select the speed when the H-O-A switch is in the "Hand" position.
- h. Speed Meter: The VFD will be furnished with a digital door-mounted speed meter (0-100 %) to indicate the rpm of the motor or the percent of full-load frequency of the VFD.
- i. The VFD manufacturer will provide "N2 bus interface card" for direct interface with Johnson Controls METASYS System.
- j. The VFD will be furnished with bypass contractors that will allow manual operation of the unit.

### 3.15.B Section 15050 - Basic Mechanical Materials and Methods

### 3.15.B.1 Housekeeping Pads and Equipment Supports

General: Pads and supports will extend a minimum of 4 inches and a maximum of 8 inches beyond the base or supporting member in all directions. It is the intent to have the pad not extend under the entire piece of equipment unless that equipment is located on the exterior of the building on the ground, or the weight of the pad is required for vibration control. Pads will have ½ inch chamfered on all exposed edges and will be poured and finished smooth and level to insure proper and continuous support for the bearing surfaces of the equipment. There will be no deviation in excess of 1/8 inch when tested with a 10-foot straightedge.

Size: Coordinate length and width of pads and penetrations necessary for piping or conduit with the actual equipment approved for use on the project.

Height: Pads will be a minimum of four inches high, or as required to maintain proper condensate drainage characteristics for the air handling unit.

### 3.15.B.2 Identification of Piping and Equipment

General: Comply with ANSI A13.1-1981, Scheme for Identification of Piping Systems, and OSHA requirements, or as otherwise indicted.

Markers and Bands: Use to identify contents of pipe and direction of flow. Required for all visible or accessible piping systems.

Valve Tags: Each tag will designate appropriate service and valve number. Used in association with the valve tag list to confirm operational data and other pertinent information.

Labels: Establishes identity for mechanical system components. Labels on access panels advise of item that is accessible through the panel.

Equipment Access: Provide access doors and panels at all locations where concealed equipment, fixtures, devices, and similar items require accessibility for service, inspection, maintenance, repair, or replacement.

### 3.15.C Section 15060 - Pipes and Pipe Fittings

Domestic Water Piping (Above Ground): Copper piping will be annealed seamless hard temper type "K" and will comply with ASTM B-88. Copper is allowed for pipe sizes up to an including 4 inch diameter. The name or trademark of the manufacturer and the type of pipe will be permanently marked on each section of pipe at intervals not exceeding 4'1/2 feet. Fittings used in copper alloy piping will be streamlined pattern, wrought or cast brass conforming to ANSI B16.22 or wrought bronze conforming to ANSI B16.15.

2-1/2 inches and smaller will be solder-type. Fittings for piping 3 inches and larger will be brazed fittings and will be braced or silver-soldered. Exposed piping in finished areas will be brass pipe or tube, chrome-plated.

Domestic Water Piping (Below Ground): Copper piping will be annealed seamless soft drawn type "K" copper tubing. Copper is allowed for pipe sizes up to an including 4 inch diameter. The name or trademark of the manufacturer and the type of pipe will be permanently marked on each section of pipe at intervals not exceeding 4-1/2 feet. Fittings used in copper alloy piping will be streamlined pattern, wrought or cast brass conforming to ANSI B16.22 or wrought bronze conforming to ANSI B16.15. Class 52 cement lined ductile iron for pipe 6 inches and larger with Rigid mechanical joint piping connections.

Sanitary Waste and Vent Piping (Above Ground): Cast-iron soil pipe, service weight, no-hub piping. Piping will comply with the requirements of CISPI 30 and ASTM A-888. Hubless joints will be "No-hub" type coupling consisting of a 24 gauge 304 stainless steel compression clamp with gasket guides, 304 stainless steel screw clamp and matching full neoprene gasket that interlocks with the housing. Coupling will comply with the requirements of CISPI 310 and ASTM C-564. Maximum size allowed for no-hub piping is 8 inches. Alternative materials will be considered on a case by case basis and will be approved prior to procurement or installation.

Sanitary Waste (Below Ground): Cast-iron soil pipe, service weight, hub and spigot piping. Piping will comply with the requirements of CISPI 301 and ASTM A-74. Joints for hub and spigot pipe will be installed with compression gaskets conforming to the requirements of ASTM C-564 or will be installed with lead and oakum. Alternative materials will be considered on a case by case basis and will be approved prior to procurement or installation.

Storm Water Piping: Same as Sanitary Waste. Piping for encasement in concrete walls or columns will be Schedule 40 PVC. Alternative materials will be considered on a case by case basis and will be approved prior to procurement or installation.

Cooling Tower Make-up Water Piping (Above Ground): Copper pipe, Type L or K.

Cooling Tower Make-up Water Piping (Below Ground): Galvanized steel pipe, Schedule 40, with galvanized threaded fittings.

Subsoil Drainage: Perforated PVC.

Steam Piping: Steel.

Condensate Piping (Steam): Copper Type DWV with soldered joints or Schedule 80 steel

Chilled Water Piping (Inside): Type K copper or steel.

Heating Water Piping (Inside): Type K copper or steel.

Chilled Water Piping (Underground): Pre-insulated steel.

Hot Water Piping (Underground): Pre-insulated steel.

Thermal Insulation (Hydronic Piping):

Chillers and chilled water piping will be insulated with cellular glass insulation: Owens Corning Foamglas, 1 ½" minimum thickness with bore coating, joint sealant, finish fabric, and finish mastic.

Condensate drain piping will be insulated with elastomeric insulation: Rubatex or Armstrong AP Armaflex.

Sprinkler Piping (Above Ground): Pipes 2 inch and smaller will be schedule 40 black steel, ASTM A-53 and UL Listed, Fittings will be malleable iron, 150 psi banded, threaded, black, ANSI B-16.3; Pipes 2 ½ inches and larger roll and grooved schedule 10 black steel pipe, ASTM A-135 and UL Listed. Fittings will be mechanical grooved coupling system, UL Listed.

Sprinkler Piping (Below Ground): Ductile cast iron class 52, UL Listed and FM Approve. Fittings will be mechanical joint cast iron, class 250.

#### 3.15.D Section 15110 – Valves

Domestic Water System: All valves in the domestic water system will be gate valves as manufactured by Crane, Milwaukee, Stockham, Nibco, and Powell. Valves 2 inch and smaller will be gate valves with bronze body and bronze trim, threaded or soldered connections. Valves 2 ½ inch and larger above ground will be butterfly valves with flanged, welded or mechanical joint connections, cast iron body with bronze trim. Valves underground will be butterfly (or ball – 2 inch or smaller) type with cast iron body and bronze trim, flanged or welded connections, and non-rising stem with square wrench nut head.

Hydronic Piping System: Gate, gate and angle gate valves can be appropriate for hydronic piping. Acceptable manufacturers are Crane, Milwaukee, Stockham, Nibco, and Powell. Other valve options include butterfly valves by Milwaukee (2 inches and smaller), and Crane, Centerline, DeZurik, and Nibco (2-1/2 inches and larger), and ball valves (2 inches and smaller) by Crane, Milwaukee, Nibco, Jamesbury and Stockham.

Double Detector Check Valves: Reduced Pressure Detector Assembly Backflow Preventor of, ASSE, FM Approved, UL Listed, with OS&Y gate valves on inlet and outlet, and strainer on inlet. Include 2 positive-seating check valves and test

cocks, bypass with displacement-type water meter, valves and double-check backflow preventor for continuous pressure application.

Pressure Reducing Valves: Pressure reducing valves will have a means of externally adjusting the outlet pressure. All internal parts subject to wear will be replaceable without removing the valve from the piping. Valves will have an integral low inlet pressure check valve, and will maintain. Acceptable manufacturer: Golden Anderson (no substitutions).

### 3.15.E Section 15185 - Pumps

#### 3.15.E.1 Basic Pump Construction

General: All pumps will comply with the following requirements unless otherwise indicated.

Casing: The casing will be designed for 175 psi working pressure and will be hydrostatically tested at 150% of the maximum working pressure. Suction and discharge flanges will be provided and drilled to ANSI Standards. Provide cast lifting lugs in pump casing. Casing will be horizontally split unless otherwise noted.

Pump Volute: Plugged drain, vent, and gauge tappings will be cast into the pump volute. The volute will be designed such that the motor and pump can be disconnected and removed, leaving the volute and piping in place.

Casing Rings: The pump case will have two replaceable bronze case wear rings (impeller wear rings), located at each impeller skirt. Each ring will be pinned or press-fit into grooved shoulders to lock the ring in place.

Mechanical Seals: Mechanical seals will be designed for operation in 225 Degrees Fahrenheit liquid. Seals will have a carbon seal ring and ceramic seat, or Ni resist seal, installed on both sides of the shaft, and will have provisions for venting and lubrication. The shaft will be steel, with a replaceable bronze shaft sleeve or collar. All pumps will be provided with mechanical seals unless specifically indicated otherwise.

Bearings: Radial and thrust bearings will be single row ball, re-grease lubricated, self-aligning type mounted in cast-iron cartridges, with 100,000 hours average life. Bearings will be removable without disconnecting the pump volute. Provide grease seals and neoprene water slingers to protect the bearings.

Base: Provide a cast-iron or steel drip rim base for each pump unit. Pump and drive unit will be aligned and bolted or welded in place on a common base plate prior to factory shipment.

Gasket: Provide cellulose fiber gaskets for the suction and discharge flanges.

### 3.15.E.2 Double Suction Pump

Certified Pump Curve: A certified pump curve for each double suction pump is required.

General: Pump will be single-stage centrifugal type with horizontal axially-split cast-iron casing.

Impeller: the impeller will be double suction type, made of cast bronze, balanced hydraulically and dynamically, keyed to the shaft and securely retained in an axial position by positive mechanical means.

Piping Connections: Suction and discharge connections will be located on opposite sides of the lower half casing, allowing removal of the rotating element without disturbing the system piping connections.

Manufacturer: Acceptable manufacturers are: Aurora, Bell & Gossett/ITT, or approved equal.

### 3.15.E.3 Domestic Water Booster Pump

The domestic water booster pump will be a UL Listed Variable Speed packaged system with 100% redundancy and alternating sequence of operation.

## 3.15.F Section 15410 - Plumbing Fixtures

Water closet, Wall Hung: American Standard No. 2258.125 (1.6 GPF) (or approved equal by Kohler Co.) white vitreous china, wall-mounted, elongated bowl, siphon jet, 1-1/2 inch back spud. Provide Sloan "Royal" Model No. 152-1.6 ES-S (1.6 GPF) water saver, automatic flush, valve system, with 24V. sensor and solenoid operator, with vandal resistant screws for the sensor cover plate, vacuum breaker, 1-1/2 inch flush connection for concealed back spud, angle stop valve and override push button. Provide each valve with a factory supplied transformer model EL-154 (no substitutions on flush valve assembly).

Provide a Zurn Series Z-1203, or approved equal, hub and spigot adjustable horizontal carrier system for siphon jet water closet. Provide a Sperzel No. 150-EEWSSCH, or approved equal, white heavy duty, open front, and extended back, toilet seat, with four bumpers.

Water closet, Handicapped, Wall-hung: Use all of the components as described in the previous paragraph, entitled, "Water closet, wall-hung." Set at raised handicapped height.

Urinal, Wall-hung: American Standard No. 6605.027 (or approved equal by Kohler Co.) white vitreous china, blowout flush action, 1-1/4 inch back inlet spud. Provide Sloan "Royal" Model No. 195-1.0 ES-S (1.0 GPF) water saver flush valve system, with 24V. sensor and solenoid operator, with tamper-proof screws for the sensor cover plate, vacuum breaker, 1-1/4 inch flush connection for concealed back spud and angle valve. Provide each valve with a factory supplied transformer model EL-154 (no substitutions on flush valve assembly). Provide a Zurn Series Z-1222 or approved equal plate type carrier system.

Urinal, Handicapped Wall-hung: Use all of the components as described in the previous paragraph, entitled, "Urinal, wall-hung." Set at lowered handicapped height.

Lavatory, Wall-hung: American Standard No. 0355.012 (or approved equal by Kohler Co.), white vitreous china, front overflow, and 4-inch centered faucet holes. Provide a Speakman Sensor-Flo, Model S-8810-BO-HTS-VRS, electronic faucet with 4-inch deck plate (with double studs), complete with transformer, 12 VDC solenoid valve, waterproof connectors, filters, braided steel flex hose, 0.5 GPM reduced flow device and spout locking device (no substitutions on faucet assembly). Provide a Zurn Series Z1231 or acceptable equal, concealed arm carrier system. Provide one piece escutcheon with rubber grommet at wall for control wire and braided tube. Provide 17 GA.C.P.P-trap, supplies and stops (no substitutions for fittings).

Lavatory, Handicapped, Wall-hung: Use all of the components as described in the previous paragraph, entitled, "Lavatory, wall-hung." Set at handicapped accessible height.

Mop Sink: Fiat Model No. TSB 100, or approved equivalent, precast terrazzo, 24-inch by 124-inch by 2-inch high, with 2-inch wide shoulders and 1/2-inch pitch towards inside, and stainless steel integral drain. Provide Fiat Model 889-CC, 24 inches long by 3 feet wide stainless steel mop hanger with three rubber grips. Provide Speakman Model No. SC-5811-RCP chrome-plated cast brass, complete with 3/4-inch hose coupling discharge, pail hook, and top brace (no substitutions for fittings).

Lavatory, Fittings for solid-surface countertop with integral bowl (Corian or similar): Provide a Speakman Sensor-Flo, Model S-8810-BO-HTS-VRS, electronic faucet, with 4-inch deck plate, complete with transformer, 12 VDC solenoid valve, waterproof connectors, filters, braided steel flex hose, auto-flo 0.5 GPM reduced flow device, and spout locking device. Provide 17 GA. C.P. P-trap supplies and stops (no substitutions for fittings). This sink configuration would be typical at a diaper changing station.

See Appendix A for standard fixture rough-in details for water closets, urinals, and lavatories.

Hydrants, Wall- or Floor-Mounted:

Interior: Recessed, wall-mounted, with hinged cover, 3/4-inch male hose thread nozzle, vacuum breaker-backflow preventer, chrome finish brass casting, with loose key-operated stem and door. Woodford Model B74, or approved equal.

Exterior: Recessed, wall-mounted, with hinged cover, 3/4-inch male hose thread nozzle, non-freeze, automatic draining, chrome finish all bronze construction, vacuum breaker-backflow preventer, with loose key-operated stem and door, Woodford Model B65, or approved equal.

3.15.G Section 15485 - Plumbing Equipment

3.15.G.1 Electric Water Heaters

Tank: Heater will be constructed with steel tank constructed to 125 psi working pressure, 300 psi test pressure and lined with borosilicate glass bonded to tank. Glass lining to be baked at 1600 Degrees F., to assure a molecular-interchange between tank and lining. Tank to be protected against electrolytic activity with replaceable factory installed anode rod and factory installed dielectric nipples.

Temperature Control: Water heater to be provided with fully adjustable temperature controls and automatic high limit control. Unit will have ASME-approved temperature and pressure relief valve properly sized for BTU capacity of the unit installed.

Insulation: Water heater will be insulated to ASHRAE 90.1-1989 standards and jacketed with manufacturer's standard heavy steel jacket.

Heating Element: Water heater will also feature 90% efficient immersion type heating elements. Incoloy sheathed elements will be provided. All units will be constructed with factory-installed heat traps to increase efficiency and reduce standby loss by a minimum of 10%.

Relief Valve: Provide ASME-rated and UL-listed temperature and pressure relief valve. Temperature setting will be 210 Degrees F., and the pressure setting will be 125 psig, unless otherwise indicated.

Drain: Provide storage tank drain and drain pan fabricated of minimum 18-gauge galvanized steel, with a minimum lip of 1-1/2 inches, and provided with a drain connection piped to the nearest floor drain unless otherwise indicated.

Testing: Each unit is to be UL-tested, and UL-listed, for service as a domestic water heater for voltage inputs as indicated on the drawings.

Warranty: Water heater will carry a limited factory warranty of 5 years. Acceptable manufacturers are as follows:

- a. Rheem
- b. Lochinvar
- c. A. O. Smith

Thermostatic Mixing Valve: Provide a thermostatic mixing valve with bronze body construction and corrosion-resistant components for each water heater serving the public toilets. Valve will be equipped with a removable union and stop and check valve, and stainless steel strainer. Unit will be a Lawler No. 66-50, with dialed thermometer and solenoid valve. The mixing valve will be enclosed within a lockable metal box.

### 3.15.H Section 15710 - Cooling Tower

Enclosure: The Landside Terminal, Airside F and Airside A have custom-designed concrete and masonry structures that form the basin, the tower walls, the fan deck, and the fan stacks.

Product: The cooling tower design is to be based on a regularly catalogued product assembly of the manufacturers.

Lintels: The tile fill will be supported by pultruded fiberglass reinforced vinyl ester resin tee section lintels capable of withstanding imposed loadings with a safety factor of 3.

Tile Fill: The tile fill will be of multi-cell design, set without mortar, in a pattern, and of sufficient height to meet the necessary design performance level. The tile fill will be of hard burned clay, with a low absorption such that it will pass a freeze-thaw test conducted in accordance with ASTM C 67. The tile fill will have a minimum crushing strength of 2000 psi over the gross area with the load is applied parallel to the cells as tested in accordance with ASTM F 67.

Mist Eliminators: The eliminators will be of the 3 pass cellular type, assembled in sections. Free water carryover will not exceed 0.05 % of the total water flow. The eliminator will be constructed of PVC conforming to ASTM D 1784, Type I, Grade 2. The mist eliminators will have a flame spread rating of 25 or less when tested in accordance with ASTM Procedures E-84.

Speed Reducer: The speed reducer gears will be rated with a service factor of 2 and designed for cooling tower service. The alarms for both the vibration switch and the oil lever switch will be transmitted to the BCS.

Fan Assembly: The complete fan assembly will provide maximum efficiency and long life while handling saturated air at high velocities. The fan will be a multi-blade design and constructed of fiberglass reinforced resin.

Drive Connection: The motor will be located outside the airstream. The stainless steel drive shaft will be full floating type with flexible couplings at both ends. Each coupling will be provided with a galvanized steel guard.

Distribution System: The distribution system for each cell will consist of two central headers, side laterals and nozzles. The header capacities will be as indicated in the cooling tower schedule on the drawings. All piping will be fiberglass or PVC. Fittings and nozzles will be PVC or ABS. The distribution system will terminate in a flange face located 6 inches below the top of the fill support beams.

Ladders: Provide stainless steel ladders that comply with OSHA requirements. Two ladders, located at opposite faces, will be provided for tower installations with more than two cells. Ladders will extend from the ground or walking surface to the top of the cooling tower working surface, unless otherwise indicated. Provide a stainless steel OSHA cage if the height of the top of the tower is more than 20 feet above the ground.

Water Level Control: Provide plastic or bronze mechanical float with adjustable linkage, unless otherwise indicated. The water level control will be provided with a still well and will be accessible without entering the tower basin.

Fan Motor: Provide totally enclosed, air over type motor located outside the air stream. Motor will be two-speed motor rated at 1800/900 rpm. Fan motor will have 1.5 service factor.

Vibration Cutout Switch: Provide switch to de-energize fan motors if excessive vibration occurs due to fan imbalance.

Maximum Permissible Sound Pressure Level: Use 0.0002 microbar as reference. Measure at 50 feet in several directions, uniformly covering 360 degrees. Do not exceed maximum permissible dB level in each of the following octave bands:

63 HZ - 73 dB	1000 HZ - 63 dB
125 HZ - 71 dB	2000 HZ - 60 dB
250 HZ - 69 dB	4000 HZ - 55 dB
500 HZ - 69 dB	8000 HZ - 50 dB

### 3.15.I Section 15800 - Air Handling Units

Solid Double Wall Construction: Units will be double wall construction with 2 inch thickness, 1-1/2 pound density fiberglass insulation. The insulation will be sandwiched between a minimum 18 gauge galvanized steel solid interior wall and the exterior wall. Removable or hinged access panels will provide access to both

sides of cooling coil, drain pan, internal fan drive, electric heating coil, and filter section.

**Condensate Drain Pan:** Each unit will have an insulated, 20 gauge stainless steel double wall drain pan for condensate drainage. The insulation will be a minimum of 1 inch thick fiberglass and the inner pan will be coated with corrosion-resistant elastomeric-based material. Threaded pipe drain connections will be provided on one side only and the pan will slope toward the connection, allowing no standing water. The drain connection will be on the side of the unit that has the condensate drain plumbing connection. If the selected air handling units have more than one drain connection, each connection will be provided with a trap and an individual drain line piped to discharge at the nearest condensate floor drain. The discharge of the individual condensate traps will not be connected together.

**Fans:** Fans will be double width, double inlet, multiblade type constructed in accordance with the American Fan Manufacturers' Association Standards. Fan wheels will be forward curve or backward inclined air foil type. Fan blades will be bonderized or galvanized steel and will be finished with baked enamel for corrosion protection. Fan shafts will not pass through their first critical speed at any cataloged rpm.

**Bearings:** Fans will be equipped with self-aligning, anti-friction pillow block ball type bearings with a minimum life of 100,000 hours.

Fan motors will be an open drip-proof when located outside the discharge air stream from the cooling coil and totally enclosed air-over type when located in the cooling coil discharge.

**Water Coils:** Coils will be leak tested to 200 psig air pressure underwater and designed for 300 psig working pressure. The coils will be continuous seamless copper tube with aluminum plate fins bonded by mechanical expansion of the tubes, unless otherwise indicated. Fin spacing will not exceed 12 per inch. Frames will be constructed of 16 gauge galvanized steel casing with copper headers brazed to tubes and threaded connections. Both supply and return headers will be provided with 1/8 inch NPT vent connection at top and bottom for venting and draining coil. The coils will be arranged for the water to counterflow in the direction of the air flow. Tube sheets will be 16 gauge stainless steel, located on each end and at a maximum of 80 inch intermediate spans with drain collars to support tubes. Return bends will be die-formed, brazed to tubes and header and will be seamless hard-drawn copper tubing. Casing channels will be free-draining, without depressions to collect moisture and contaminants or to block fin area, and with an air bypass/water carryover arrester between the casing bottom channel and the fins.

**Electric Coils:** Electric heating coils will be UL, ETL, or ARL listing for installation in a section of the air handling unit. Coils less than 5 kw will be single stage; above 5 kw will have a minimum of two stages. Electric heater element will be

constructed of heavy-duty nickel chromium. 480 volt, three phase elements will be internally wye connected with automatic line break high limit control. Each heater will be provided with single point electric power connection and terminal strip connection for control wiring.

Whenever possible, fan coil units, necessary for the odd situation, will be installed in a vertical configuration and within a nearby mechanical room.

### 3.15.J Section 15845 – Variable Air Volume Terminal Units

VAV units will be double wall construction with no insulation exposed to the air stream.

VAV unit controls will be Johnson Controls “Metasys” type and be factory installed.

VAV units will be located as close to the finished ceiling as possible. Units will be accessible by using a ladder no taller than eight feet.

### 3.15.K. Section 15855 - Diffusers, Registers, and Grilles

Supply diffusers, return air grilles, and exhaust grilles mounted in ceilings will have a painted perforated metal face. Round, square, or rectangular devices with exposed directional blades are not allowable. Linear devices are allowable and generally preferred by architectural designers.

### 3.15.L Section 15890 – Ductwork

Sheet Metal Ductwork:

Material: Prime quality 48 inch wide resquare tight coat cold-rolled hot-dipped galvanized steel capable of double seaming without fracture. Conform to the requirements of ASTM A-525 and ASTM-G90 for a minimum galvanizing coat of 1.25 ounces per square foot total for both sides.

Construction: Provide corner closures. Longitudinal seams and transverse joints will be flat and smooth inside. Make slip joints in direction of air flow. Transverse joints will be Pittsburgh lock or double corner seam. Button punch snaplock construction is not acceptable. All welds will be continuous and corrosion-resistant.

Fittings: Fabricate offsets, turns, and elbows with centerline radius equal to 1-1/2 times diameter when possible. No mitered offsets will be allowed.

Insulation: All supply return, and outside air ducts will be externally insulated. Unless detailed system design dictates otherwise, external insulation will be minimum 2" thick fiberglass duct wrap where concealed and 1 ½" thick duct board where exposed. Continuity of the vapor barrier on the exterior insulation will be maintained in accordance with the manufacturer's instructions. Duct insulation within equipment rooms will be fully coated with mastic or painted in its entirety.

Double Wall Manufactured Ductwork:

Material: Duct will be double wall, machine formed round or flat oval spiral lock seam duct constructed of galvanized steel sheets. The inner wall will be perforated and the annular space will be filled with minimum 1" glass fiber insulation with a maximum "k" value of 0.27 BTU per square foot per hour. Insulation will be covered with a minimum 1.5 mil film so that no fibrous material is exposed to the airstream.

Flexible Ducts:

Insulated Flexible Ducts, Fiberglass: Flexible duct will be factory-fabricated pre-insulated type with seamless vapor barrier. Fiberglass insulation will be nominal 1 inch thickness with maximum thermal conductance of 0.23 BTU/hr-sq. ft.-degrees F. at 75 degree F. mean temperature. Flexible duct will have an operating pressure range of minus 0.5 inch w.g. to plus 2 inch w.g., maximum working velocity to 4000 fpm and temperature range to 250 degree F. Core will be continuous and consist of aluminized mylar laminated to a corrosion resistant steel wire helix.

Vapor retardant rating will be 0.17 perm maximum per ASTM E96-A.

Flexible duct will be a maximum of 8 feet in length unless otherwise indicated and will be fully extended to smooth out internal corrugations, and will be installed without kinks, compression, or obstructions so that pressure drop is minimized. Install with a maximum equivalent of two 90-degree bends. No bend will be made with centerline radius of less than one duct diameter for fiberglass ductwork, or four and one-half diameters for metal ductwork. No additional flexible duct will be provided for future relocation unless otherwise indicated; cut and remove excess length.

Flexible duct will be supported at ends and at each 90-degree bend. Maximum permissible sag is ½ inch per foot of spacing between supports.

Hanger and saddle material in contact with the flexible duct will be of sufficient width to prevent any restriction of the internal diameter of the duct when the weight of the supported section rests on the hanger or saddle material. In no case will the material contacting the flexible duct be less than 1 inch wide. Hanger will be used in conjunction with a sheet metal saddle formed to cover one-half the circumference of the outside diameter of the flexible duct and will be rolled to fit neatly around the lower half of the duct's outer circumference.

Ducts and pipes within mechanical rooms will not be supported from the floor. Coordinate ductwork and piping to allow clear access to and around equipment.

### 3.15.M Section 15900 – HVAC Instrumentation and Controls Airside E

For the Landside Terminal complex, Airside F, Airside A, Airside E, and the new Airside C, the Building Control System is, and will be the Johnson Controls "Metasys" system installed by the manufacturer.

With a Johnson Controls system, all AHU and chiller plant control valves and dampers will be pneumatically actuated. In addition, all VAV control dampers will be electronically actuated.

All new and revised control drawings will be laminated and inserted in the master set in the HVAC Control Room (Service Building at the Central Plant).

### 3.16 Division 16 - Electrical

#### 3.16.A Section 16050 - Basic Electrical Materials and Methods

A City of Tampa Electrical Permit must be obtained and displayed at the work location.

All work must conform to the National Electrical Code, the City of Tampa Code, the Authority Tenant Work Permit General Construction Standards (Special Provision No. 4) and the applicable Authority Design Criteria Manual.

All relays, contactors, starters, motor control centers, switchboards, panelboards, dry-type transformers and so forth, will be supplied and manufactured by the same manufacturer. Panelboards, switchboards, breakers, etc., will match the existing building equipment.

All screws, bolts, washers, and other fasteners used in supporting fixtures, conduit, or outlets will be fabricated from rust-resisting metal and will be of a common replacement type design. No rivets or other non-replaceable type fasteners will be permitted. Use of tie wire is not acceptable. Gunpowder-set anchors are not permitted.

Provide reinforced concrete "housekeeping pads" for switchgear, motor control centers, transformers, etc. Pads should be a minimum of 4 inches high and project at least 6 inches beyond the footprint perimeter of the cabinet. Pads should match existing pads within the same room. Chamfer top edges 1/2 inch.

Testing of cables 600V or less and size No. 2 or larger will be meggered using an industry-approved "megger" with a minimum of 500V internal generating voltage. All inspection, cleaning and testing procedures will be in compliance with the recommendations and standards outlined in the "Maintenance Testing Specifications for Electrical Power Distribution Equipment and Systems," latest edition, published by International Electrical Testing Association (NETA).

Readings will be recorded in the presence of a Design Engineer or an Owner's Representative. Provide a schedule of testing to the Engineer and the Authority construction project manager a minimum of three calendar days prior to testing. Insulation resistance test values will be no less than 50 megaohms.

### 3.16.B Section 16060 - Grounding and Bonding

All branch circuit and feeder raceways will have a copper system ground conductor within the conduit throughout the entire length of the circuit and bonded to portions of the conduit that are metal by listed grounding bushings.

### 3.16.C Section 16075 - Electrical Identification

Equipment identification using phenolic plastic laminate nameplates will be as follows:

- a. Normal system will be 1/2-inch high white lettering on a black field
- b. Emergency system will be 1/2-inch high white lettering on a red field
- c. Uninterruptible power supply system will be 1/2 inch high white lettering on an orange field

### 3.16.D Section 16110 – Raceways

The entire installation will be in hot-dipped rigid galvanized conduit, intermediate metal conduit, heavy wall Schedule 40-PVC plastic conduit (in slab or underground only), or electric metallic tubing, unless specifically noted otherwise. Only heavy wall PVC (Schedule 40) will be used for all raceways trapped underground and in or under concrete slab on grade. Minimum conduit size for lighting, power, data, phone and fire alarm systems will be 3/4-inch C. All conduit will be UL-listed and labeled.

Conduit expansion fittings will be malleable iron, and will be hot-dipped galvanized inside and outside.

All raceways will be run in a neat and workmanlike manner, and will be properly supported from structural members (beams, joists, or slabs) in accordance with the latest edition of NEC using approved conduit clamps, hanger rods, and structural fasteners. Supporting conduit and boxes with wire is not approved. All raceways except those from surface-mounted switches, outlet boxes or panels, will be run concealed from view. Exposed raceways will be supported with clamp fasteners, with toggle bolt on hollow walls, and with lead expansion shields on masonry. Where PVC penetrates a floor from underground or in slab, a black mastic coated steel conduit elbow will be used. No PVC will be allowed anywhere except underground or in slab. Conduits will be run parallel and perpendicular to building beams wherever possible, exposed or concealed, and will be grouped in

workmanlike fashion. Crisscrossing of conduits will be minimized. Multiple runs of raceways will be routed together. Raceways will not be located within six inches of other system components (HVAC ducts, chilled water lines, sprinkler lines, domestic water lines, bus ducts, etc.).

The Contractor will prepare and submit coordination review drawings to Authority prior to installation of all multiple raceway conditions illustrating layout, elevations, and coordination with other building system components. All raceways will be installed as close as possible to the structure and at the highest elevation possible. All raceways will have an insulated copper system ground conductor throughout the entire length of circuit installed within conduit in strict accordance with NEC.

Insulated bushings will be used on all rigid steel conduits terminating in panels, wire gutters, or cabinets.

All connections to motors or other vibrating equipment (except dry type transformers) or at other locations where required will be made with not less than 12 inches of flexible liquid-tight steel conduits, using special type of connectors with strain relief fittings at both terminations of conduit.

Expansion fittings will be installed in the following cases: In each conduit run wherever it crosses an expansion joint in the concrete structure; on one side of joint with its sliding sleeve end flush with joint, and with a length of bonding jumper in expansion equal to at least three times the normal width of joints; in each conduit run which mechanically attaches to separate structures to relieve strain caused by shift on one structure in relation to the other; in straight conduit run above ground which exceeds one hundred feet in length. Interval between expansion fittings in such a run will not be greater than 100 feet.

Electric metallic tubing (thin wall) may be installed inside buildings above ground floor where not subject to mechanical injury. All electrical metallic tubing will be joined using compression type steel fittings. All connectors will have insulated throats.

Rigid metallic conduit installed underground will be coated with waterproofing black mastic before installation, and all joints will be recoated after installation.

All temporary and permanent conductors (power, lighting, control, communications, lightning protection, etc.) must be placed in conduit or approved cable trays.

The Contractor will furnish coordination drawings prior to installation which show layout and elevations of all multiple raceways.

Bus ducts will be separately supported using the manufacturer's standard recommended equipment allowing for removal of bus duct sections and inspection of all cover plates.

The minimum conduit size for power and lighting systems will be 3/4 inch conduit for all circuitry homeruns from the panelboard. Conduits branching off of the homerun conduit to devices may be 1/2 inch conduit, if it contains no more than 4 conductors per conduit (excluding the equipment grounding conductors), and phase conductors no larger than No. 12 AWG.

All systems (fire alarm, sound system, controls, etc.) conduits will be a minimum of 3/4 inch.

Catwalks and handrails will not be used to support raceways of any type.

All raceways crossing building expansion joints will be equipped with expansion-type fittings.

Sleeves will be used when conduits pass through walls, floors, and roofs, and will be of galvanized steel, sized to allow for a minimum 1/4 inch clearance. Fire rating integrity will be restored after penetration.

Flexible steel conduit will be limited to final connections to motors and transformers and will be restricted to 36 inches in length. Flexible steel conduit may also be used to connect light fixtures to junction boxes in lengths not to exceed 4-6 feet. All flexible steel installations will be a continuous length with threadless hinged clamp-type fittings and a male end provided with a locknut.

All conduit must have steel compression-type connectors and couplings with non-removable insulated throats.

All conduit exposed to the weather will be rigid galvanized conduit.

All raceways (conduits, wireways, busways, etc.) and boxes will be independently supported from the building structure. Attachment to ceiling support system or the use of tie wire for raceway support is prohibited.

All raceways and boxes will be installed as close as possible to the structure and at the highest elevation possible. The Contractor will prepare "coordination drawings" that establish MEP systems layering to ensure proper functioning and maintenance access for all ceiling cavity components.

All raceways will be installed parallel with the structural framing members.

Raceways and boxes will not be located within six inches of other systems (HVAC ducts, chilled water lines, sprinkler lines, water lines, bus ducts, etc.).

Multiple runs of raceways (two or more) will be routed together and supported by trapeze hangers consisting of all-thread rod and unistrut cross members. All multiple raceways will be installed horizontally. Conduit supports will be one-hole

malleable straps, clamp-backs, or other accepted devices with suitable bolts. Caddy batwing-style straps, which clip to wire without the use of bolts, are not allowed.

Floor Boxes: Design type will allow for continuous raceway into the floor boxes without a junction box. Floor box raceways will be installed to allow for the first junction box to be located within the same room and floor level.

Maximum allowable wire or cable fill in a raceway will be 40%. This applies to all systems (fire alarm, low voltage controls, fiber optic, telephone, etc.).

Spare parts will be provided at the completion of the work as follows:

- a. Lamps: Provide a minimum of one case or six lamps, whichever is greater, for every type of lamp installed. Quantity may be increased with large-scale projects.
- b. Fuses: Provide a fuse cabinet with 3 spare fuses of each size and type used.

### 3.16.E Section 16120 - Conductors and Cables

Branch circuit and feeder conductors for electric power will be copper type THW or THWN. No aluminum wiring will be permitted. Wire in vicinity of heat-producing equipment will be type XHHW/L-S insulation. All wiring will be manufactured in the USA.

All copper taps and splices in No. 8 or smaller wire will be fastened together by means of "wirenut" connectors. All taps and splices in wire larger than No. 8 will be made with solderless type lugs and taped to provide insulation equal to wire. Stranded conductors #2 and larger should have compression type connectors.

All power feeders and branch circuits No. 8 and smaller will be wired using color-coded wire having the same color used for a system throughout the building. Power feeders above No. 8 will be either fully color-coded or black insulated and be similarly color-coded with tape in all junction boxes and panels. Tape will completely cover 1/3 of the length of conductor insulation within the box or panel.

Modular connectors, MC, AC, or any similar type cable wiring are prohibited. The intent is to allow removal of conductors without conduit replacement. All electrical wiring will be performed by conventional, industry standard methods with the use of conduit, wire, and wire nuts.

All electrical feeders will be run in continuous pieces without joints or splices.

All conductors will be copper. Branch circuit and feeder conductors No. 12 AWG and smaller will be solid. No. 8 AWG and larger will be stranded.

Cable extensions from raceway terminations will not exceed 5 feet.

Connections: Conductors No. 10 and smaller will be connected with pre-insulated twist-on spring connectors encased in a plastic shell and rated at not less than 105 degrees C. No exceptions. Wire nut manufacturers will be Ideal or accepted substitution. A minimum of 3/8-inch skirt will cover all bare wires. Self-stripping or stab-in type electrical wire connectors are prohibited. This includes connectors within lighting fixtures, signs, and equipment.

### 3.16.F Section 16130 – Raceways and Boxes

At all concealed boxes for electric lights, switches, wall receptacles, telephone outlets, etc., standard galvanized one-piece steel boxes will be provided. Surface outlet boxes and conduit bodies will be made of heavy cast aluminum or iron with external raised hubs. Trim rings will be of one-piece construction.

Boxes will be of such form and dimensions as to be adapted to the specific use, location, type of device or fixtures to be used, as well as number and size of conductors and arrangement, and size and number of conduits connecting thereto.

All flush boxes will be mounted so that covers and plates will be flush with finished surfaces without the use of shims, mats, or other devices. Plates will not support wiring devices. Where two or more switches are installed in the same location, gang switches together using one-piece boxes with common plate. Wall-mounted devices of different systems (switches, thermostats, etc.) will be coordinated for symmetry when located near each other on the same wall. Trim rings will be extended to within 1/8 inch of finish wall surface.

Installation of outlet or junction box will be limited to one extension box. Flush outlets will be mounted so that covers and plates will finish flush with finished surfaces without the use of shims, mats, or other devices not submitted for this purpose. Add-a-Depth rings or switch box extension rings (Steel City #SBEX) are not acceptable. Plates will not support wiring devices. Arrange switches together with a common plate where two or more are indicated in the same location. Wall-mounted devices of different systems (switches, thermostats, etc.) will be coordinated for symmetry when located near each other on the same wall. Through-wall type boxes will not be permitted.

### 3.16.G Section 16140 - Wiring Devices

Wiring devices will be specification grade. Switches will be silent type. Receptacles will be duplex grounding type, and will be provided at a maximum spacing of twenty-five feet in public areas.

Coverplates for all devices will be stainless steel. All outside receptacles (weatherproof) will be duplex grounding type with stainless steel hinged covers.

Voltage and ampere rating of switches will be marked on switch, and will conform to voltage of system to which applied.

Use 20 AMP premium specification grade receptacles. Provide hospital-grade receptacles in all areas used by housekeeping (corridors, public areas, etc.). All devices (switches, receptacles, etc.) will be terminated with side-wired screw terminals only. Stab-in wire connections held by spring tension are not permitted.

Color of devices will be ivory with stainless steel coverplates.

### 3.16.H Section 16190 - Supporting Devices

All supports, hangers, and inserts required to mount fixtures; conduit, cables, and pullboxes will be furnished and installed. All items will be supported from the structural portion of the building. Boxes and conduits will not be supported or fastened to ceiling suspension wires or to ceiling channels.

All conduits will be securely fastened in place at intervals of 10 feet maximum. Hangers, supports, or fastenings will be provided at each elbow and at the end of each straight run terminating at a box or cabinet. The use of perforated iron for supporting conduits will not be permitted. The required strength of the supporting equipment and size and type of anchors will be based on the combined weight of conduit, hanger, and cables.

Hangers will be made of durable materials suitable for the application involved.

With concrete or masonry construction, insert anchors will be installed with round head machine screws. An electric or hand drill will be used for drilling holes for all inserts in brick, concrete, or similar construction. CAUTION: No anchors or holes will be made in the structure without first consulting with the Structural Engineer of Record.

### 3.16.I Section 16289 - Transient Voltage Suppression

Provide external Transient Voltage Surge Suppression (TVSS) on the following conditions:

- a. Service entrance equipment
- b. Panelboards (with circuits serving known electronic equipment)
- c. Systems panels (fire alarm, security access control, computer clean power, etc.) on both the power feed and any wiring (signaling circuit, initiating device circuit, etc., shields), which extend beyond the building by either underground, aerial, or other methods such as walkways, bridges, etc. Also, device wiring located at high locations such as penthouses, parking garage roof levels, etc., should be included.

- d. Spark gap devices or devices incorporated in or installed within the panel in lieu of the external TVSS are not acceptable.

#### 3.16.J Section 16415 - Automatic Transfer Switch (ATS)

Automatic Transfer Switch (ATS) will have a manual bypass isolation operating handle with transfer speed equal to automatic operation. Provide automatic and manual transfer switches manufactured by one of the following:

- a. Russelectric, Inc.
- b. Automatic Switch Company
- c. Zenith Company

#### 3.16.K Section 16425 - Distribution Switchboards

Factory-assembled, metal-enclosed switchboard for distribution and control of power from incoming line terminals to outgoing feeder terminals, installed and tested in place.

Switchboard will include all protective devices and equipment as listed on drawings or as included in these specifications, with necessary interconnections, instrumentation, and control wiring.

##### 3.16.K.1 Products – General

Switchboards with circuit breaker, fusible switch, or integrally fused circuit breaker branch protective devices will comply with NEMA PB2 as a minimum requirement. Switchboard will meet Underwriters' Laboratories enclosure requirements for service conditions.

Each cubicle will have UL label affixed, unless special construction prohibits and no labeling or listing is available.

The sides and tops will be covered with removable screw-on code gauge steel plates.

Switchboards will be completely self-supporting structures, 90 inches high.

##### 3.16.K.2 Finish

All steel surfaces will be chemically cleaned and treated to provide a bond between paint and metal surfaces to help prevent the entrance of moisture and formation of rust under the paint film.

The switchboard exterior will be finished indoor light grey No. 61, ANSI Z55.1.

Apply corrosion-protective undercoating to undersurface.

### 3.16.K.3 Bussing and Terminations

Bus bars:

- a. Buses will be tin-plated copper sized on the basis of not more than
- b. The bus structure will be braced to withstand mechanical forces exerted during short circuit conditions as required to limit the system fault current.
- c. A copper ground bus will be furnished secured to each vertical section structure.

Bus connections will be front accessible.

When spaces for future devices are noted on the drawings, all necessary buses except for the device connecting straps will be furnished.

Where provisions for future sections are called for on drawings, all buses will be extended to last section, and be adaptable for extension.

Through bus that feeds additional sections to main section will have continuous current rating of 100% of rating of main device frame size.

Line and load terminations will be provided suitable for the size, number of conductors, and conductor material. Terminations will be accessible from the rear.

Provide full-height wiring gutter doors for quick access to wiring terminals.

All hardware will have high tensile strength, and have a suitably protective finish.

When called for on drawings, a bus duct stub will be suitable for a direct connection to the bus duct without cabling.

### 3.16.K.4 Accessories

A switchboard will be provided with adequate lifting provisions, and will be capable of being rolled or moved into installation position and bolted directly to the floor without the use of floor sills.

### 3.16.K.5 Control Wiring

Each control wiring conductor will have heat shrink identification labels on each end of termination. Terminations will be made to screw terminal strips using approved conductor terminals. All points of terminal strips are to be labeled to match conductor labeling.

### 3.16.K.6 Main Section

The following instruments and associated equipment will be provided when called for by the designer or the Authority

- a. Ammeter
- b. Voltmeter
- c. Ammeter and voltmeter transfer switches
- d. Current and potential transformers required
- e. Fuses
- f. All interconnecting wiring required

Instruments to be 4-1/2 square with +1 % accuracy, panel mount type.

Ground fault protection system will be provided.

- a. System will consist of a ground sensor on line side of main switch or on load side of branch breaker encircling all phase conductors, including neutral connected to a solids ate ground relay switch which initiates shunt tripping of the main or branch circuit interrupting device.
- b. System on main incoming service will be adjustable from 200 to 1200 primary amperes, system on branch breakers will be adjustable from 50 to 200 primary amperes, and time current characteristics should provide 6 cycle operation at about ten times setting.
- c. Relay output will operate from 120v AC fused sources from main bus.
- d. Submit coordination diagram relays and demonstrate coordination.

### 3.16.K.7 Distribution Sections

Circuit breaker, fusible switch, or integrally fused circuit breaker branch protective devices will be group-mounted with necessary bar connections accessible from the front, and have a minimum interrupting rating as required to limit the system fault current.

### 3.16.L Section 16430 - Switchgear

All switchgear will be equipped with the following:

- a. Current carrying parts of the bus structure will be copper
- b. The neutral will be fully rated
- c. Provide a copper equipment grounding bus of the set screw type

Circuit breakers for applications other than panel boards will be bolt-on type.

Electrical distribution will be similar to Airsides A, E, and C with two TECO transformers and the main building switchgear in two sections with an open tie breaker.

Provide spare switchgear breaker for the largest size breaker and a space within the switchgear to house. Provide spare capacity for future.

### 3.16.M Section 16440 - Disconnect Switches

All disconnect switches will be heavy-duty type, unless specifically noted otherwise. Switches will be fusible or non-fusible and sized as noted on drawings.

Switches will be 240 volt rated on systems up to and including 120/208V and 600V rated on higher voltage system with NEMA 1 enclosure, unless otherwise noted. All switches for motors will be dual horsepower rated. All switches mounted outdoors will be NEMA type 4X (stainless steel).

Provide and install lugs on disconnect switches as required to accept conductors.

### 3.16.N Section 16442 - Panelboards

Panelboard branch circuit breakers will be bolt-on, thermal-magnetic, molded case type.

Panelboards will be equipped with a minimum of 3 spare breakers and 25 % spare capacity.

All panelboards will be equipped with the following:

- a. Current carrying parts of the bus structure will be copper.

- b. The neutral will be fully rated.
- c. Provide a copper equipment grounding bus of the set screw type.

### 3.16.O Section 16450 - Grounding

In general, all electrical equipment (metallic conduit, motor frames, panel board, etc.) will be bonded together with a green insulated or bare copper system grounding conductor in accordance with the specific requirements of Article 250 of the NEC. Insulating bonding conductor through the raceway system will be continuous from main switch ground bus to panel ground bar of each panel board, and from panel grounding bar of each panel board to branch circuit equipment and devices.

A main ground, bare copper conductor, NEC sized but in no case less than No. 2/0, will be run in conduit from the main switchgear to a driven ground field outside the building. The main building service grounds will have resistance to ground at no more than 5 OHMS.

Grounding conductors will be so installed as to permit shortest and most direct path from equipment to ground; be installed in metal conduit with both conductor and conduit bonded at each end; have connections accessible for inspections and made with approved solderless connectors brazed (or bolted) to the equipment or structure to be grounded; in no case be a current carrying conductor; have a green jacket unless it is bare copper; and be run in conduit with power and branch circuit conductors. The main grounding electrode conductor will be exothermically welded to ground rods.

All contact surfaces will be thoroughly cleaned before connections are made to ensure good metal-to-metal contact.

Mechanical lugs or wire terminals will be used to bond ground wires together or to junction boxes and panel cabinets and will be manufactured by Anderson, Buchanan, Thomas and Betts Company, or Burndy.

All exterior grade mounted equipment will have their enclosures grounded directly to a separate driven ground at the equipment in addition to the building ground connection.

### 3.16.P Section 16461 - Transformers

Dry type transformers will be factory assembled, metal enclosed, provided, and installed in place.

Dry type transformers will be UL-listed and certified to meet NEMA ST-1 with convection cooling. Transformers will be tested and rated for sound level in accordance with ASA-C89. 1-1961.

Class H insulation will be employed for transformers above 30 KVA with maximum temperature rise of 150 degrees C. over 40 degrees C ambient. Class F insulation will be employed for transformers up to and including 30 KVA with a maximum temperature rise of 115 degrees C. over 40 degrees C ambient. Transformers will be copper wound.

Three phase units will be wound delta-wye. Minimum impulse level will be 10 KV. Each three phase transformers will have three separate sets of coils. No Scott T connections, open delta, or two coil arrangements will be permitted.

Transformers will be mounted where accessible. No units may be mounted behind partitions, above ceilings, etc. Each transformer will be mounted on 3-inch concrete base extending 3 inches beyond all sides.

#### 3.16.Q Section 16442 - Panelboards

Panelboards will be of dead front design, equipped with bolt-on, quick-make, circuit breakers of the thermal magnetic type and mains with lugs or main breakers are required. Panel bus will be tin-plated copper. Bus will be braced for a capacity equal to or greater than the available symmetrical fault current. Double and triple pole breakers will be of common trip, single handle type.

Typical cabinets will be surface-mounted (concrete or masonry walls) or flush-mounted (gypsum board/stud walls) and will be fabricated from galvanized steel with a standard baked enamel finish.

Panels and breakers will be rated for voltage and class of service to which applied. All panels will have locks and all will be keyed alike. Panels will be supplied with standard baked enamel finish, both back box and front, except flush panels will have galvanized backbones. All panel board cabinets will have a system grounding bar bonded to the panel board cabinet for connection of system grounding conductors system. This bar will be mechanically and electrically isolated from the neutral bar. Panel fronts on flush panels will have completely concealed trim clamps and door hinges. A typewritten circuit direction listing the actual circuit numbers, type of load and room names will be mounted on inside of door.

### 3.16.R Section 16475 - Overcurrent Protective Devices

#### 3.16.R.1 Description of System

Provide overcurrent protection for all wiring and equipment in accordance with the NEC, all federal, state and local codes as required and/or as shown on the drawings.

#### 3.16.R.2 Circuit Breakers

Circuit breakers for lighting and appliance panelboards will be bolt-on type. Circuit breakers for power panelboards will be bolt-on.

All circuit breakers will be molded-case, quick-make, quick-break, thermal magnetic type, and will be UL-listed and rated for voltage and class of service to which applied.

Double and triple pole breakers will be of the common trip, single handle type.

Circuit breakers will have minimum rating of 10,000 amp interrupting capacity, unless required otherwise by the design engineer.

#### 3.16.R.3 Fuses

No fuses will be installed until equipment is ready to be energized and after tightening of all electrical connections, inspection of all ground conductors and a meggar test of adequate insulation to ground of all circuits.

Fuses rated 601 amperes and larger will be UL Class L and have a minimum time-delay of 45 seconds at 300% rating and have O-ring gas seals at the end bells.

Fuses rated 600 amperes or less, installed ahead of circuit breaker or circuit breaker panels, will be UL Class RK-1.

Fuses rated 600 amperes or less for all general power circuits will be dual-element, UL Class RK-5-time delay type. They will be self-protected from extraneous heat.

#### 3.16.R.4 Spare Fuse Cabinet

10% (or a minimum of three) of each size and type of fuse will be placed in a spare fuse cabinet, wall-mounted near the electric service.

Cabinet will be sized as required to store all fuses neatly. Cabinet will contain shelves and /or slots as required to separate types of fuses. Cabinet door will be hinged with latch.

#### 3.16.R.5 Identification Label

A fuse identification label, showing type and size, will be placed inside the door of each fused switch.

Labeling for rejection type fused switches will read:

WARNING!  
USE ONLY CURRENT LIMITING FUSES  
CLASS \_\_\_\_\_, TYPE \_\_\_\_\_, MFR \_\_\_\_\_

Label will be engraved in red laminated plastic.

#### 3.16.S Section 16511 - Interior Lighting

All fixtures will be designed and installed with consideration for maintenance accessibility. Stairwell fixtures will be located so they are accessible from a ladder at each landing.

All public restroom fixtures will have battery backup in addition to an emergency circuit. Emergency circuit will have a key switch located in an accessible janitor's closet to allow for annual battery discharge.

Use photo controls in lieu of time locks whenever possible. Lighting control contactors will be electrically and mechanically held. (This allows for manual closing of a contractor when needed.)

All lighting fixtures and signs will be equipped with a renewable fuse in an external GLR fuse holder. Fuse placement will be in the most readily accessible location. An example would be to locate the pole-mounted fixture fuses at the bottom of the pole accessible from the handhold.

#### 3.16.T Section 16670 - Lightning Protection

Lightning protection system will be designed in compliance with provisions of NFPA No. 780, "Standard for the Installation of Lightning Protection Systems."

The lightning protection system will be placed on the structure by experienced installers in compliance with provisions of the NFPA and Underwriters' Laboratories. Installers will be LPI (Lightning Protection Institute) certified, master, and journeyman in accordance with LPI standards. A UL Master Label and LPI certification will be required for the system.

Materials will comply in weight, size, and composition with the requirements of UL and the NFPA relating to this type of installation, and will be UL-labeled.

Air terminals will be solid copper with nickel-plated point, and will have proper base support for surface on which they are attached and will be securely anchored to this surface. Terminals will project a minimum of 10 inches above top of object to which attached.

Conductors will consist of commercially pure copper, complying with the weight and construction requirements of the Code, and will be cased to interconnect with air terminals and, in general, provide a two-way minimum path to ground. The angle of any turn will not exceed 90 degrees, and will provide an approximately horizontal or downward course. Down conductors will be installed in concealed plastic conduit. Radius of bends will not be less than 8 inches.

Conductor fasteners will be of the same material as the conductor, having ample strength to support conductor. Where fasteners are to be mounted in masonry or structural work, they will be furnished to the Contractor for installation during the construction of the project.

Ground connections will be made in accordance with requirements of all applicable codes. Ground rods will be placed in a minimum of two feet from building foundations. In addition to above artificial grounds, one down conductor of each two-path system will be connected to water piping system with approved water pipe type strap connector.

### **3.17 Telecommunications Infrastructure Standards**

#### **3.17.A General**

The Hillsborough County Aviation Authority currently specifies the requirements for the installation and use of copper and fiber optic telecommunications cabling to support voice, data, video, security and other low voltage applications and services at Tampa International Airport. This Document describes the general requirements, standards, specifications, and methods of execution pertaining to the telecommunications cable infrastructure for use at the Airport. It includes the furnishing, installation, testing and documentation of telecommunications copper and fiber optic cable, terminations, outlets, and related items for use throughout the Airport facilities.

##### **3.17.A.1 Reference Standards**

- a. The publications listed below form a part of the telecommunications infrastructure requirements to the extent referenced. The publications are referred to in the text by basic designation only. All publications are intended to be the most current editions available.

- b. Except where otherwise noted all material and workmanship will conform to the following standards:
- (1) TIA/EIA-568-B Commercial Building Telecommunications Wiring Standard (most current edition) - This document specifies a generic telecommunications cabling system for commercial buildings that will support a multi-product, multi-vendor environment. It includes cabling components, transmission, system models, and the measurement procedures needed for verification of balanced twisted pair cabling and optical fiber cabling systems.
  - (2) TIA/EIA-569-A Commercial Building Standard for Telecommunications Pathways and Spaces (most current edition) This document encompasses telecommunications considerations both within and between buildings. The aspects covered are the pathways into which telecommunications media are placed and the rooms and areas associated with the building used to terminate media and install telecommunications equipment. It includes requirements for conduits, cable trays, surface mounted raceway (i.e., Wiremold, etc.), modular furniture systems, floor access systems, equipment rooms and wiring closets.

Notes: 1. Particular attention is to be given to Basic Building Elements - Telecommunications Closets and Equipment Rooms. There will be a minimum of one Telecommunications Closet established for each floor of a building.

2. Each Telecommunications closet will be provided with a lockable door that, if practical, will be integrated with TPAs' Access Control System. If this isn't possible, the door will have a lock compatible with the existing IT / Telecommunications' closet lock.

- (3) TIA/EIA-606-A Administration Standard for Telecommunications Infrastructure of Commercial Buildings (most current edition) - This document provides guidelines and choices of classes of administration for maintaining telecommunications infrastructure. It includes standards for naming conventions and labeling for telecommunications spaces (equipment rooms and wiring closets), backbone cables and horizontal links. It also includes administration, naming and labeling of fire-stopping and grounding/bonding materials and locations. TPA

adopted a detailed telecommunications labeling and naming convention with which contractors must comply for all installations (see Section 3.18).

- (4) J-STD-607-A Commercial Building Grounding and Bonding Requirements for Telecommunications (most current edition) - The purpose of this standard is to enable the planning, design, and installation of telecommunications grounding and bonding systems within a building with or without prior knowledge of the telecommunications systems that will subsequently be installed. This standard also provides recommendations for grounding and bonding of customer owned towers and antennas. This telecommunications grounding and bonding infrastructure supports a multi-vendor, multi-product environment as well as various system installation practices.
  
- (5) TIA/EIA-758 Customer Owned Outside Plant Telecommunications Cabling Standard (most current edition) This document provides requirements used in the design of the telecommunication pathways and spaces, and the cabling installed between buildings or points in a customer-owned campus environment. Customer-owned campus facilities are typically termed "outside plant" (OSP). For the purpose of this standard, they are termed "customer-owned OSP".
  
- (6) ASTM E 814-00 Fire Tests of Through-Penetrations Fire Stops (most current edition) - This standard provides a test method that is applicable to through-penetration fire stops of various materials and construction. In this case, the standard refers to fire stops that are intended for use in openings in fire-resistive walls and floors for the purpose of passing telecommunications cables, conduits, cable trays, etc. This test method also measures the resistance of fire stops to an external force stimulated by a hose stream.
  
- (7) NFPA National Electrical Code (most current edition) – This document covers electric conductors and equipment installed within or on public and private buildings or other structures, including mobile homes and recreational vehicles, floating buildings and other premises such as yards, carnivals, parking, other lots and industrial substations; conductors that connect the installations to a supply of electricity; other outside

conductors and equipment on the premises; copper and optical fiber telecommunications cable; abandoned telecommunications cable; buildings used by the electric utility such as office buildings, warehouse, garages, machine shops, and recreational buildings that are not an integral part of a generating plant, substation, or control center. Section 800 of the NEC pertains to electrical safety issues relative to telecommunications installations.

- (8) The Florida Building Code and any and all other local, county and State building codes, regulations and ordinances.

### 3.17.A.2 Submittals

- a. **Materials & Equipment List:** Prior to installation the contractor will submit for approval a complete list of materials, equipment, accessories, configurations and installation methods proposed for work in accordance with these specifications. The list will include complete catalog identification numbers and models or system designator, quantities, options and catalogs "cuts."
- b. **As Built Drawings:** The contractor will provide one set of reproducible drawings depicting the final installation details, including final cable locations, quantities and routing, upon completion of the project. The contractor will also provide as built drawings in electronic format. The formats are to be determined by TPA at the time of implementation of the project.
- c. **Cable Management System Documentation:** The contractor will provide a listing in spreadsheet format of all horizontal and riser cables, indicating type of cable, origination and termination points and length. The contractor will provide this spreadsheet in electronic format, in Microsoft Excel (latest version available), using a specific spreadsheet format provided by TPA. The data will be entered into TPA's Cable Management System.
- d. **Record Drawings:** The contractor will maintain and keep up to date a complete record set of drawings that will show every change from the Contract Drawings.
- e. **Room Labeling:** Initial and all subsequent submittals will include a labeling scheme that reflects the labeling standards delineated in section 3.18 of the Design Criteria Manual.

### 3.17.A.3 Delivery, Storage, and Handling

- a. The contractor will deliver materials factory packaged in containers or

reels. All materials will be stored in a clean dry space as specified by TPA. The contractor will handle all materials carefully to avoid damage.

- b. The contractor will inspect each reel of cable for physical damage. Any reel or cable container found to be damaged to the extent that cable integrity may be affected will be returned to the supplier for replacement. Prior to installation, the contractor will inspect all hardware (distribution shelves, connectors, etc.). Any damaged or faulty equipment will be replaced.

### 3.17.B Products

#### 3.17.B.1 General

TPA has established standards for products to be used for telecommunications infrastructure to be installed at the Airport. These standards are established to ensure commonality of services throughout the Airport regardless of manufacturer, vendor or owner.

#### 3.17.B.2 Fiber Optic Backbone Cable Subsystem

- a. Single mode fiber cable used will have the following optical characteristics:

Size: Core/Cladding      8 to 9/125um

Attenuation: 1.00 dB/km at 1310nm - tight buffered, inside plant

1.00 dB/km at 1550nm - tight buffered, inside plant

0.50 dB/km at 1310nm - loose tube, outside plant

0.50 dB/km at 1550nm - loose tube, inside plant

- b. Multimode fiber cable used will have the following characteristics:

Size: Core/Cladding      50/125um

Attenuation: 3.5 dB/km at 850nm

1.2 dB/km at 1310nm

Bandwidth: 160MHz at 850nm

500MHz at 1300nm

- c. Fiber optic cable will be rated by the manufacturer for use in high speed wide and local area network environments.

- d. Inside backbone cable will consist of tight-buffered single mode cable consisting of multiple fiber bundles and a dielectric central strength member. The outer jacket will meet the NEC requirements for OFNR rating.
- e. Outside plant fiber cable will be of water-blocked, loose tube, single mode construction. The cable will consist of multiple fiber bundles surrounding a dielectric central strength member, and covered with a fire resistant jacket.
- f. Acceptable manufacturers: Corning, Optical Cable Corporation, Superior Essex, Comm Scope, Berk-Tek or approved equal.

### 3.17.B.3 Fiber Distribution Panels

- a. Panels used for terminating outside plant and inside building fiber optic cables will be of the distribution type. Where feasible, all fiber distribution panels will be rack mounted. Panels will be low profile, and selected to occupy minimum rack spaces.

Distribution panels will have both termination bays and splice bays, with the proper number of LC panels/mounting plates with stainless steel couplers and splice organizer trays plus 20% for expansion.

- b. Acceptable manufacturers: Panduit, Avaya, Siecor, Leviton or approved equal.

### 3.17.B.4 Fiber Cable LC Connectors

- a. LC compatible connector couplings will be able to accommodate ceramic or plastic LC compatible connectors. The contractor will use couplings specifically rated by the manufacturer for high-speed applications.
- b. Multimode and single mode fiber connectors will be stainless steel LC compatible, epoxy type, with ceramic tips. The maximum average insertion loss specifications will be as follows:

(1) Single mode: .4dB/connector

(2) Multimode: .4dB/connector

Acceptable manufacturers: Panduit, or approved equal.

### 3.17.B.5 Fiber Optic Patch Cables

- a. Fiber patch cables will be appropriate length duplex LC-to-LC fiber patch cords for all fiber distribution panel ports.

- b. The contractor will provide cable management rings and support brackets for routing and support of all fiber patch cables.
- c. Acceptable manufacturers: Panduit, Avaya, Siecor, Leviton, or approved equal.

#### 3.17.B.6 Interior Copper Cable Backbone Subsystem

- a. The interior copper cable backbone system will consist of the following:
  - (1) Multi-pair copper cable meeting the NEC standard for CMR-rated cable. All cable will meet NEC Article 800 low-flame/low smoke requirements suitable for use without conduits.
  - (2) Horizontal 110-type wiring blocks mounted in all wiring closets.
- b. The contractor will provide cable management rings and support brackets for routing and support of all interior copper backbone cables.
- c. Interior copper backbone cable will be UTP Category 3 cable minimum and will be in compliance with the TIA/EIA standards.
- d. Acceptable manufacturers: Avaya, Berk-Tek, Superior Essex, or approved equal.

#### 3.17.B.7 Outside Plant Copper Cable Subsystem

- a. Outside copper cable will be gel-filled to inhibit water penetration, and armored to resist rodent and other penetration-type damage. Outside copper cable will meet RUS PE-89 specifications.
- b. Acceptable manufactures: Avaya, Norcom-CDT, Superior Essex, or Approved equal.

#### 3.17.B.8 Cable Voltage Protection

The contractor will provide gas-tube voltage protection blocks for outside plant cables. Voltage protection blocks will be wall mounted with locking front cover. Acceptable manufacturers: RELTEC, Porta Systems or approved equal.

#### 3.17.B.9 Horizontal Cable Subsystem

- a. The horizontal cable subsystem will consist of Category 6A foil shielded or higher UTP and six strands of multimode, armored, fiber optic cable end-to-end installation as identified in the latest TIA/EIA

568-B standard. Copper cables will consist of 4 twisted pair cable; either PVC-jacketed or plenum-rated as required in the environment where work is occurring. All cable will meet the following requirements:

- (1) Category 6A foil shielded cable will meet all performance requirements as specified in the most current version of the TIA/EIA 568-B.
- (2) Unless otherwise specified, the standard category 6A foil shielded cable complement will be two 4-pair data cables and two 4-pair voice cables. All category 6A foil shielded cable will be color coded and placed in the face plate as follows:

Cable	Cable Color	Insert Color	Placement
Voice/Data 1	Blue	Blue - if available	Upper - 2 <sup>nd</sup> from Left
Voice/Data 2	Blue	Blue – if available	Lower – 2 <sup>nd</sup> from Left
Voice/Data 31	Blue	Blue – if available	Upper Left
Voice/Data 4	Blue	Blue – if available	Lower Left
Fiber 1	Blue and Orange	Electric Ivory	Center Right
Fiber 2	Green and Brown	Electric Ivory	Upper Right

- (3) Unless otherwise specified, the standard fiber installation will consist of two, two-strand fiber connections placed below the copper connections on the face plate as shown in section 3.18, page 4, of the DCM.
  - (4) Unless otherwise specified all CAT 6A jacks will be Panduit part numbers CJS6X88TGY.
  - (5) Unless otherwise specified all fiber jacks for the faceplates will be Panduit part number CMDJLCEI.
  - (6) Unless otherwise specified all double-ganged faceplates will be Panduit part number CFPF12EI-2G and all single gang faceplates will be Panduit part number CBEI.
- b. Horizontal copper cable runs will not exceed 90 meters from the outlet to the IDF. If cable routing requires horizontal runs in excess of 90 meters, the contractor will notify TPA in advance of installation.

- c. All fiber horizontal cable will be 6 strand, 50/125 multimode (OM3) micron cable.
- d. Acceptable manufacturers: Panduit or approved equal for fiber; Panduit, Corning, Optical Cable Corporation or Superior for copper cable.

#### B.17.B.10 Station Cable Faceplates and Jacks

- a. All data/voice faceplates used will have a capacity of a minimum of six outlets utilizing a double-ganged box that is 4 inches wide and as deep a physically permissible.
- b. Data, voice and fiber communications jacks will meet all performance requirements as specified in the latest issue of the TIA/EIA 568-B and will be wired to accommodate the T-568B wiring sequence.
- c. Faceplates will be flush mounted. Any surface mounted boxes must be approved in advance by TPA.
- d. Fiber inserts on the faceplate will have recessed inserts with a downward slope of 30 degrees.
- e. All modular jacks & plugs used will comply with FCC part 68 specifications.
- f. No metal faceplates will be used.
- g. Acceptable manufactures: Panduit or approved equal.

#### 3.17.B.11 Category 6A Patch Panels

- a. Category 6A patch panels will meet the TIA/EIA requirements for Category 6A foil shielded cross-connect and switching hardware.
- b. The contractor will provide Category 6A, RJ45 patch panels in all wiring closets adequate to support all installed Category 6A foil shielded cables (data and voice), plus 20% growth in each wiring closet.
- c. Category 6A patch panels will include wire management components that will be used for routing of communications cable to and from telecommunications panels and equipment. These components will include:

- (1) Wire slots to organize cables

- (2) Cable brackets for support and routing
  - (3) Strain relief clips
  - (4) Wire management panels
- d. Acceptable RJ45 patch panel manufacturers: Panduit, or approved equal.

3.17.B.12 Fiber Optic Distribution Panels

- a. Fiber Optic Patch Panels will meet the TIA/EIA requirements for fiber optic switching hardware.
- b. The contractor will provide Fiber Optic LC patch panels in all wiring closets adequate to support all installed fiber optic cables plus a 20% growth in each wiring closet.
- c. Fiber Optic Distribution Panels will include wire management components that will be used for routing of communications cable to and from related Fiber Optic source equipment.
  - (1) Wire slots to organize cables
  - (2) Cable brackets for support and routing
  - (3) Strain relief clips
  - (4) Wire management panels
- d. Acceptable manufacturers: Panduit or approved equal.

3.17.B.13 Equipment Racks

- a. In each wiring closet the contractor will mount RJ45 patch panels and fiber distribution panels in floor-mounted, 84" high, 19" equipment racks with cable management troughs. Furnish and install adequate racks to support rack-mounted fiber optic distribution panels and category 6A, RJ-45 patch panels, and 20% growth.
- b. Acceptable manufacturers: B-Line, Chatsworth, X-Mark or approved equal.

3.17.B.14 Category 6A foil shielded Patch Cables and Fiber Optic Cross-Connect Cables

- a. The contractor will provide adequate Category 6A patch cables and Fiber Optic cross-connect cables of appropriate lengths to support all patch panel ports and Fiber Optic distribution panels installed.
- b. The contractor will not be responsible for installing patch cables. This specification only calls for furnishing the patch cables to be installed by others.
- c. Acceptable manufacturers: Avaya, Leviton, Siemon, Corning, Optical cable Corporation, Comm Scope, Berk-Tek or approved equal.
- d. Prior to purchase of patch cables, contractor will consult Aviation Authority Telecom Group concerning cables length to be supplied.

3.17.B.15 Fiber and Cable Management

- a. Drop-downs of Copper and Fiber cables will be accomplished utilizing conduit "waterfall", Panduit Part Number CMW-KIT, and waterfall accessories as appropriate. The contractor will consult with the Aviation Authority Telcom Group to clarify any questions on this matter.
- b. Acceptable manufactures: Panduit or approved equal.

3.17.C Execution

3.17.C.1 Installation

a. General Instructions

- (1) The contractor will install all provided and furnished materials in accordance with manufacturer's specifications, recommendations and guidelines. Copies of the manufacturer's guidelines, specifications and recommendations will be provided by the contractor to TPA and will be made available on site to the contractor's personnel.
- (2) Install all wiring and cabling in accordance with the National Electric Code (NEC) where the provisions of the NEC are applicable.
- (3) Installation will be in conformance to generally acceptable telecommunications means and methods and the manufacturers' specifications. Stress on any cable during

installation will not exceed manufacturers' specifications. All splicing and connectorization will be in accordance with industry-standard practices.

- (4) The contractor will coordinate installation of all cabling to promote ease of installation and efficient use of rack space, backboard space, conduits and cable trays.

b. Fiber Optic Cable Plant Installation

- (1) All fiber cable will be terminated in LC connectors mounted in fiber distribution centers. The contractor will use fiber pigtailed and splice trays at all distribution points.
- (2) All Backbone fiber optic cables will be installed in innerduct tubing to protect and isolate it.
- (3) ALL Horizontal fiber optic cables will be six strand, armored, multimode and fiber optic cable
- (4) Fiber optic cable will be installed in accordance with manufactures specifications. The contractor will not exceed the maximum pulling tension or minimum bend radius of the cable.

c. Copper Outside Plant Installation Requirements

- (1) All outside plant cables will be terminated in 110 blocks.
- (2) All copper outside plant cable will terminate in voltage protection units upon entering the wiring closet in each building.
- (3) All copper outside plant copper cable will be installed in accordance with manufacturers' specifications. The contractor will not exceed the maximum pulling tension or minimum bend radius of the cable.

d. Copper Inside Plant Backbone/Riser Subsystem

- (1) All cables will be terminated in 110 blocks.
- (2) All copper inside plant copper cable will be installed in accordance with manufacturers' specifications. The contractor will not exceed the maximum pulling tension or minimum bend radius of the cable.

e. Horizontal Cabling

- (1) The standard for horizontal distribution systems will consist of a complete Category 6A installation, using foiled, non-plenum rated UTP cables and/or fiber optic cables where national and local codes will allow for such installation. Any cable designated to be routed in spaces identified as riser or return air plenum spaces will conform to the installation requirements for these spaces by national and local codes, such as the use of riser and plenum rated cables.
- (2) Electrical service boxes identified for use as communications outlets will be connected to the accessible ceiling locations via continuous and integral electrical metallic tubing (EMT) conduit, at a minimum. This conduit will be routed between the CO and the accessible ceiling designated communications cable tray where the end of the conduit will terminate no further than 6" to 12" from the point of cable tray exit, and in such a manner that there is no requirement to support the communication cable between the cable tray and the CO conduit. This CO and conduit installation is a TPA requirement. If any deviation from this requirement is proposed by the contractor, the contractor will obtain explicit written permission from TPA for only the specified points of installation.
  - (a) If CO service boxes and integral conduit runs do not exist or specifically provided by others, then it will be the responsibility of the contractor to furnish and install them. The minimum installation requirements will be a double-gang box and a 1" conduit run. The conduit run will be provided with swept conduit bends, not to exceed 180° in total, such that the conduit run is horizontal to the ceiling and at the same level of the accessible ceiling communication cable tray within ±3 inches vertically.
  - (b) All conduits will be reamed to remove sharp inside edges and any open conduit end will have a bushing installed to protect the communications cable jacket.
  - (c) All conduits will be adequately supported at 48" intervals or less.
  - (d) It is understood that certain communications outlet conduit installations may be impractical due to pathway

and space limitations such as routing, penetrations and architectural aesthetics. For such conditions, the contractor is required to submit an alternate pathway design and rationale for TPA approval.

- (e) When any cable is pulled through a CO conduit, an internal dragline is to be left in place to facilitate the installation of future cables.
- (3) Between the end of the conduit stub-up and the wiring closet, the contractor will install appropriate cable tray of appropriate capacity to accommodate the expected full build-out at the area of the building facility being served. It is the expectation of TPA that cable tray be used in horizontal distribution. The contractor will install the appropriate cable tray support hardware. In no instance will the contractor attach cables to any other support hardware in the ceiling space. The cable tray will be supported at 48" intervals or less. The weight of maximum cable capacity will dictate a more frequent support.
- (a) At locations where a cable tray cannot be accommodated due to floor/wall penetrations, structure and/or aesthetics, the cable routing must transition to other types of pathways. The contractor will utilize cable bridle rings attached to hanger rod supports to secure the cable to the point of entry of the alternate pathways. Cable at these transition points between the cable tray and alternate pathways will be supported at spacing of 48" or less depending on the weight of the bundle.
  - (b) Under no circumstances will cable be laid on suspended ceiling or draped across other conduits, pipes, ducts, or other facilities installed along the path of the cable.

f. Route Preparation, Drilling and Coring

Field coordination with TPA will be required prior to installing cable trays (where specified), sleeves, wall or floor penetrations and/or cables.

g. Termination

- (1) The contractor will terminate all conductors of all cables. Each copper outside plant and riser cable pair will be terminated contiguously on wall-mounted 110 blocks. Terminations will be in color code sequence from left to right and from top to bottom on each block for each cable. 110 blocks will be labeled in a permanent legible fashion, in compliance with TPA's approved labeling scheme.
- (2) Fiber strands will be field terminated in rack-mounted fiber distribution panels on LC connectors according to the specification of the manufacturer. Only tool kits and consumables that are specified by the manufacturer will be utilized. Completed LC connectors will be placed into the sleeve of the fiber termination panel from left to right in color code sequence. Strands will be protected and secured within the fiber panel to ensure both strain relief and bend radius. The fiber cable will be tie wrapped (this means the total cable with all strands inside of outer jacket) at the point of entry of the patch panel to prevent strain on the strands. Where required, to secure the fiber optic cable from pulling tension, the Kevlar strength members will be separated from the fiber strands and attached to the panel by a clamp. Fiber connectors will be terminated on LC connectors using manufacturer-approved methods.
- (3) The contractor will terminate horizontal cables in modular jack inserts at the outlet in accordance with the floor plans, using the T568B wiring sequence.
- (4) The contractor will terminate horizontal cables on rack mounted Category 6A, RJ45 patch panels and/or Fiber Optic Fiber Distribution Panels according to the T568B wiring sequence.

h. Site Survey

- (1) Prior to placing any lateral, riser or outside plant cable, penetration, etc. the contractor will survey the site to see that job conditions do not impose any obstructions that would interfere with the safe and satisfactory placement of the cables, and arrange to remove any obstructions with TPA. The contractor will provide shop drawings for approval by TPA prior to starting work.
- (2) The contractor is responsible for notifying TPA as soon as field conditions prevent proper installation.

- (3) The contractor will verify site conditions and dimensions of equipment to ensure access for proper installation of equipment without disassembly that will void warranty, and will report in writing to TPA prior to purchase or shipment of equipment involved, on conditions that may prevent proper installation.

i. Inspection

All cable will be inspected as it is pulled off the reel for any obvious defects. If defects are observed, further use of the cable from this reel will be halted.

j. Pulling Tension

- (1) No cable will be installed with a pulling tension exceeding the maximum recommended by the manufacturer. Pulling tension should be monitored with a tension gauge.
- (2) If multiple cables are to be pulled at one time, the contractor will make the necessary allowances to back off the pulling tension of the bundle.
- (3) Cable pulls will be protected by means of an overload cutoff or breakaway clutch set at least 10% below the cable manufacturers' maximum recommended pulling tension.

k. Bend Radii

All cables will be installed with a bend radius greater than recommended by the manufacturer.

l. Slack

- (1) The contractor will install sufficient slack prior to termination and patching.
- (2) Prior to termination, the contractor will be required to leave slack for riser cables to provide some degree of flexibility and for service rearrangement.

m. Securing Methods

- (1) The contractor will provide tie wraps, riser cable support grips, vertical and horizontal cable trays in wiring closets and other equipment spaces based upon field conditions to maintain orderly cable organization.

- (2) The contractor will be responsible for securing all cabling in a way to satisfy any structural engineering requirements.
- (3) The contractor will obtain required structural engineering related information for any item that may affect the infrastructure of the building, and submit the information to TPA for prior review and approval.
- (4) The contractor will provide suspended platforms, threaded rods, strap hangers, brackets, shelves, stands or legs as necessary for floor, wall or ceiling mounting of equipment provided under this Section. The contractor will provide steel supports and hardware for proper installation of hangers, anchors, guides, etc., and will provide cut sheets, weights, and other pertinent data required for proper coordination of equipment support.
- (5) Velcro® tie wraps will be used at approximately 60-inch intervals to secure cable in cable trays and to provide strain relief at termination points.

n. Placing Cable in Conduit

- (1) The contractor will verify that any conduits to be employed are clear of obstructions unless TPA has approved an exception in writing. For fiber, inner duct will be placed in conduit. A fish line and mandrel will be used to clear conduits of obstructions and as a guide for pulling the cable through.
- (2) For riser cable, the cable strength members will be affixed to the pulling medium or, a properly sized 'kellum' type grip will be employed to make the pull. Cable pull tension will be monitored during the pull with a tension meter as necessary and if mechanical pulling equipment is used, a clutch set at 10% below the cable manufacturer's maximum pulling tension will be used.
- (3) A nylon dragline will be pulled along with each conduit run installed so that future cables may be pulled in that conduit. Conduit bushings will be used to protect the cable jacket from abrasion as it is pulled through conduit and at each exposed end.

o. Lubrication

As necessary, for cable pulls in conduit, the contractor will use only an approved lubricant compatible with the cable's outer jacket insulation.

p. Protection

During installation, and prior to final acceptance, the contractor will protect finished and unfinished work against damage and loss. In the event of such damage or loss, the contractor will replace or repair such work at no additional cost to TPA. As cable is installed, care must be taken to avoid nicks, kinks or other damage to the cable. Cable is to be labeled at each end as specified. Provide strain relief at each termination point and 24 inches of slack to allow for easy re-termination of the cable, if required later.

q. Cable Routes and Clearances

Unshielded twisted pair cable will be routed so as to maintain the following minimum distances from power sources:

Condition	Minimum Separation Distance		
	<2 kVA	2-5 kVA	>5 kVA
Unshielded power lines or electrical equipment in proximity to open or nonmetal pathways	127 mm (5 in)	305 mm (12 in)	610 mm (24 in)
Unshielded power lines or electrical equipment in proximity to grounded metal conduit pathway	64 mm (2.5 in)	152 mm (6 in)	305 mm (12 in)
Power lines enclosed in a grounded metal conduit (or equivalent shielding) in proximity to a grounded metal conduit pathway		76 mm (3 in)	152 mm (6 in)
Electrical motors and transformers			1220 mm (48 in)

r. Grounding

- (1) All metallic sheathed cables will be bonded and grounded. Riser cables will be bonded to the metal frames of the mounting hardware in the wiring closet using bonding clamps appropriate to the size of the cable.
- (2) Each wiring closet will have a single ground point. This point is bonded to the integral building grounding system or to the local structural steel. All grounding and bonding in each wiring

closet will be connected to that point either directly or through the use of ground bus connections.

- (3) All cables with a metallic component, which enter a wiring closet from outside a building, will be grounded at the point of entrance with appropriate lightning protection.

s. Splicing

No splicing of any cables will be performed unless otherwise explicitly noted in the Drawings or pre-approved in writing by TPA.

t. Materials Management

- (1) Equipment and materials will be properly stored, adequately protected and carefully handled to prevent damage until acceptance.
- (2) The contractor will ensure delivery of cable, factory-packaged in containers or on reels. Storage of all components will be provided by the contractor including rental of containers or other suitable methods as specified.

u. Fire Stopping

- (1) The contractor will suitably fire stop all riser shaft openings; horizontal sleeve penetrations, both ends of any horizontal conduits and all slot cuts in walls and under the raised access floors which are needed to facilitate cable access/egress.
- (2) The contractor will verify to TPA's satisfaction that the integrity of all fire stops is maintained upon completion of the work.

v. Protection/Restoration of Premises

The contractor will, as required, during the progress of work, remove and properly dispose of resultant dirt and debris, hang protective plastic sheathing when specified and keep premises clean. Upon completion of work, the contractor will remove equipment and unused material provided for work.

w. Quality Assurance

- (1) The work will be executed in full accordance with the current rulings of the latest applicable standards and all rulings by state, utility, and local authorities. Where codes conflict, the

more stringent will apply. Where the specification requirements exceed the requirements of these authorities, codes, and standards, the specification requirements will prevail.

- (2) The contractor will replace any imperfect or rejected work with work conforming to the requirements of the specification and will be satisfactory to TPA without extra cost to TPA.
- (3) The contractor will report to TPA promptly in writing, whenever plans or specifications are believed to be at variance with these requirements and will not proceed with such work until further instructed in writing by TPA.

x. Abandoned and Future Cabling

- (1) Abandoned cable will be removed from all pathways and spaces by the contractor anywhere the contractor is conducting new installations, renovations or replacement of existing cable plant backbone or horizontal pathways and space.
- (2) Abandoned cable will be identified by the contractor, in consultation with TPA, for each project. Any cable later identified by the contractor as possibly abandoned will be brought to the attention of TPA.
- (3) Any un-terminated communications cabling identified for future use by the TPA will be documented by the contractor pursuant to the TPA's cable management system specifications.

3.17.C.2 Testing

a. General Instructions

- (1) For projects with a contract value in excess of \$25,000, testing will be performed by an independent testing agency, retained by and at the expense of the contractor. For projects valued at \$25,000 or less, inspections will be performed by the contractor.
- (2) The contractor will thoroughly test, or have tested, all cables and connectors that they furnish and install. TPA requires certification that all pairs were tested and found to be 100% reliable end-to-end (block-to-block and block-to-receptacle); bad pairs/punch-downs and/terminations will not be used, but rather be corrected and/or replaced at no additional cost to

TPA. The contractor will present all testing plans to TPA for approval prior to the start of testing.

- (3) The contractor will provide a complete description of acceptance testing procedures and will notify TPA upon successful completion of acceptance testing.

b. General Rules

- (1) The contractor will provide all labor, test equipment, and tools necessary to verify proper operation prior to final acceptance by TPA.
- (2) Prior to any testing, the contractor will provide TPA with a two day minimum advance notice of the date testing is to begin. All test results shall be documented, and submitted to TPA for review, prior to final acceptance by TPA.
- (3) The contractor will repair or replace all cable, connectors, and equipment supplied by the contractor, which do not meet acceptance criteria, prior to final acceptance by TPA.

c. Replacement

- (1) Any cable, connector, or wiring block, patch panel or other device furnished by the contractor which tests below manufacturer's standards will be replaced at no additional cost to TPA. The replacement will be re-tested to verify compliance.
- (2) Successful completion of all tests indicated below is required for acceptance.

d. Testing Procedures

- (1) The contractor will provide the necessary test equipment to conduct the tests.
- (2) Field tests may be required to be performed in the presence of TPA and/or its duly authorized representatives. The contractor will provide written documentation reporting the results of all tests.

e. Pre-Installation Testing

The contractor will obtain factory test data for each reel of cable including, but not limited to:

- (1) Physical Production Tests (tensile strength)
- (2) Transmission Production Tests
- (3) To ensure that all specifications and standards are maintained within manufacturer's specifications, the contractor will provide to TPA the Manufacturer's Test Certification for each reel of cable.

f. Fiber Optic Cable Test Procedures - Backbone and Horizontal

- (1) Following the physical installation and termination of the fiber optic cables, the contractor will conduct any pre-checkout tests deemed necessary prior to the conduct of formal acceptance tests with the Owner.
- (2) The contractor will verify continuity of all optical fiber strands.
- (3) The contractor will be responsible to perform optical loss (attenuation) measurements and Optical Time Domain Reflectometer (OTDR) tests. contractor will document such items as the personnel involved in the testing, type of equipment utilized, equipment settings, the date tested, reel number (or cable ID when tested post-installation) and strand number. The contractor will be responsible to supply sufficient cable for the installation and to take whatever action is necessary to provide such cable at no additional cost to TPA.
- (4) The contractor will provide written certification, including actual trace records in As Built Drawings that the optical loss for each strand is within the limits established.
- (5) If a fiber cable loss exceeds either the established optical loss or the manufacturer's standards, the contractor will first clean the connections at both ends and retest the cable. If loss is still excessive, the contractor will inspect the connections. Repolishing or connector replacement may be required. If the connector terminations are determined to be acceptable, the cable may be defective. An Optical Time Domain Reflectometer (OTDR) will be used to locate cable breaks and points at which losses occur.
- (6) In the event that the fiber continues to test outside of acceptable specifications, the contractor will replace the cable at no additional cost to TPA in accordance with TPA's schedule.

g. Acceptance Testing

The contractor will perform the tests and inspections described in this section in the presence of TPA. Each floor and closet will be tested individually and accepted on a per floor basis. The cabling system will be tested for compliance with the specifications for physical placement, electrical specifications, wiring accuracy, continuity, and proper labeling and identification. Document all test results.

h. Physical Inspection

Prior to conducting any transmission testing, the following visual inspections will be performed:

- (1) Verify that cable has been installed to comply with contract documents.
- (2) Check for physical damage to Distribution Panels and Termination Blocks.
- (3) Verify that outlets have been securely mounted and properly labeled.
- (4) Check that all cabling is properly jacketed, installed and labeled at both ends (to the appropriate block/panel in the TR).
- (5) Verify that all cable bends are within the manufacturer's minimum bend radius allowed.
- (6) Check and demonstrate that all cable shields have been correctly grounded or bonded.
- (7) Verify that the cable is properly supported for termination and long-term placement (approvals must be obtained from TPA).
- (8) Verify that all cables are properly supported and independent of any other support/hanger rods in the ceiling space.
- (9) Verify that cables have been terminated properly and in proper color code sequence.

i. Copper Cable Transmission Tests

- (1) Electrical tests of copper cables will be performed only with connectors installed and cables punched down. Copper Riser

and horizontal cables will be tested End-to-End from termination point to termination point via the appropriate punch-down on the termination block. 100% TESTING OF ALL PAIRS ON ALL CABLES IS REQUIRED. Manufacturer standard test equipment will be employed in addition to any special test gear required.

- (2) All pairs of each cable will be electrically tested for:
  - (a) Continuity - the measured resistance value will be recorded.
  - (b) Opens
  - (c) Ground Faults
  - (d) Correct Termination - for the unshielded twisted pair, the correct color code will be punched down to be appropriate block/pin on the 110 block.
  - (e) Reversals (Correct Polarity)
  - (f) Splits
  - (g) Crosses
- (3) The contractor will create a punch list of bad pairs and re-terminate and, as necessary, replace any defective cables, connectors and/or panels.

j. Horizontal Station Cable Testing - Copper

- (1) Perform testing, and certify Category 6A compliance on all horizontal cable subsystems. All components of each horizontal subsystem must be of the Category 6A rating (cable, jack insert, patch panel, patch and station cables), and the entire link, including all components, must be tested end-to-end. Test results will be documented on hard copy media and listed by outlet.
- (2) The contractor will identify the test equipment and procedures that will be followed to complete and document the testing.
- (3) Test measurements will be conducted for bandwidth up to 625MHz, and include the following:

- (a) Insertion loss
- (b) Delay
- (c) Delay skew
- (d) NEXT
- (e) PSNEXT
- (f) Return loss
- (g) ELFEXT
- (h) PSELFEXT
- (i) ACR
- (j) PSACR

### 3.17.C.3 Cable System Documentation

#### General Instructions

- a. The contractor will provide documentation enumerating termination panels and every cable run. Any additional documentation not explicitly listed that the contractor feels should be provided to facilitate a complete, working installation prior to acceptance by TPA will also be supplied.
- b. Documentation of all installed cable, manhole racking diagrams and splicing diagrams will be provided in an electronic database suitable for direct entry into TPA's cable management system. Fiber optic OTDR test results will be provided in hardcopy format.

### 3.17.C.4 Cleaning

- a. The contractor will clean up all work areas at the end of each day, removing all cartons, debris, emptied containers, etc. as the work progresses.
- b. Just prior to inspection for substantial completion the contractor will perform all final cleaning and sealing of equipment required to bring the installation to optimum appearance.3.16.A

## 3.18

### Aviation Authority Labeling Standards

Aviation Authority has implemented a labeling scheme for the labeling of all telecommunications cable, faceplates, patch panels, wiring blocks and equipment racks.

### Building Identifiers

Each building on the airport property is designated by a two-character code as shown below.

<u>Designation</u>	<u>Building Name</u>
AA .....	Airside A
AB .....	Airside A Baggage Sort Bldg
AC .....	Airside C
AE .....	Airside E
AF .....	Airside F
AM .....	Airfield Maintenance
BR .....	Blue Car Rental
CB .....	Cargo Building
CF .....	Canine Facility
CL .....	Cell Lot
CS .....	Customs Bldg
EP .....	Economy Remote Garage
EV .....	East Airfield Electrical Vault
FB .....	Airside F Baggage Sort Bldg
FS .....	Fire station
FX .....	Federal Express Building
GA .....	Guard Shack for A/S A
GB .....	Check Point Bravo
GC .....	Guard Shack for A/S C
GE .....	Guard Shack for A/S E
GF .....	Guard Shack for A/SF
LP .....	Long Term Parking
NP .....	North Parking Lot
PO .....	Post Office
RB .....	Raytheon Building
RR .....	Red Car Rental
SB .....	Service Building
TB .....	Terminal Building
TP .....	Toll Plaza
WV .....	West Airfield Electrical Vault

### Telecommunications Spaces

Telecommunications Rooms are defined using a seven (7)-character designation. The designation consists of the following:

Characters 1 & 2 - Building designation (i.e., TB = Terminal Building)

Characters 3 & 4 – Floor designation (i.e., 04 = 4<sup>th</sup> floor, 71 = 71 foot level)

Characters 5, 6 & 7 – Room number (i.e., 880 = room 880)

A list of current Telecommunications Spaces follows.

Terminal Building

<u>Location</u>	<u>Designation</u>
4th floor Switch Room	TB04880
1st floor A Core Bag Make-up	TB01280
1st floor B Core Bag Make-up	TB01380
1st floor C Core Bag Make-up	TB01680
1st floor D Core Bag Make-up	TB01780
2nd floor Comm. Room	TB02680
48' Level A Core	TB48180
48' Level B Core	TB48480
48' Level C Core	TB48580
48' Level D Core	TB48880
71' Level A Core	TB71180
71' Level B Core	TB71480
71' Level C Core	TB71580
71' Level D Core	TB71880
91' Level A Core	TB91180
91' Level B Core	TB91480
91' Level C Core	TB91580
91' Level D Core	TB91880

Service Building

Maintenance Work Control – IDF	SB01480
Switch Gear Room	SB01580
Mezzanine (East)	SB0M103
Mezzanine (West)	SB0M104
P&D IDF	SB02383
Police IDF	SB02580
Communications Center IDF	SB02581
Rental Car Garage Support	SB01481

Long Term Parking

High Vehicle MDF	LPHV680
Elev. Mach. Room A	LP91880
Elev. Mach. Room B	LP91580
Elev. Mach. Room C	LP91180
Elev. Mach. Room D	LP91480
Toll Plaza Office DATA IDF	TP02581
Toll Plaza Office Voice IDF	TP02580

Airsides

A/S-A MDF	AA01580
A/S-A IDF-A	AA01780
A/S-A IDF-B	AA01680
A/S-A IDF-C	AA01380
A/S-A Comm. Room	AA01180
A/S-A Comm. Room	AA01181
A/S-C MDF	AC01780
A/S-C IDF ----West	AC01480
A/S-C IDF ----East	AC01280
A/S-E MDF	AE01380
A/S-E IDF-A	AE01880
A/S-E IDF-B	AE01680
A/S-E IDF-C	AE01280
A/S-E IDF-D	AE03380
A/S-E Shuttle Car Bay	AE01480
A/S-F MDF	AF01980
A/S-F Shuttle Car Bay	AF01981
A/S-F TE	AF01480
A/S-F TE	AF01680

Outlying Buildings

Canine Facility MDF	CF01114
Airfield Maintenance MDF	AF02209
Fire Station MDF	FS01370
Customs Bldg MDF	CS01980
Economy Parking Garage	EP01980

## Backbone Cable Designations

Backbone cable designations will be based on the near-end and far-end of the cable. For example, a backbone cable from the 71 foot level, D Core of the Terminal Building to the Airside A MDF will be designated "TB71880/AA01580."

For backbone cables between telecommunications spaces within the same building, the building designation is dropped from the cable designation. For example, a cable between Airside A MDF and Airside A IDF-A will be designated "01580/01780."

In general, the 1<sup>st</sup> part of the cable designation is defined as the near-end cable termination point and the 2<sup>nd</sup> part of the cable designation is defined as the far-end.

Cable labels will be placed no more than three (3) inches from each end of the cable.

In cases where more than one cable exists between the same two points, the cable designation will include a modifier to indicate multiple cables, as in the following example:

1<sup>st</sup> Cable – AA01580/TB71880-1

2<sup>nd</sup> Cable – AA01580/TB71880-2

In cases where cables originating from different locations terminate in the same Telecommunications Space, each cable will be terminated on a separate patch panel or wiring block.

### Faceplates and Jacks

Faceplates will be labeled as illustrated on the following sketch:

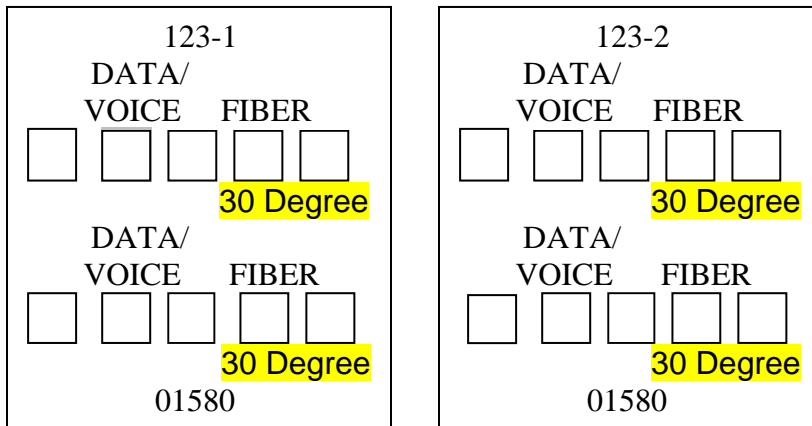

In the above examples:

1. The faceplate labels include the faceplate identification number on the top, which consists of the room number (123) and the faceplate number in the room (-1) or (-2). In rooms with multiple faceplates, the numbering system begins with the first faceplate to the left of the entrance door, as you enter, and proceeds clockwise around the room.
2. The faceplate labeling also includes the identification of the Telecommunications Space (TS, wiring closet) in which the jacks terminate. Note that when labeling the faceplate, the two character building designation does not need to be applied.
3. Typically, there will be multiple jacks on each faceplate. Each jack on the faceplate will have a designation. Unused jacks will have “blanks” inserted into their slots. On the double-gang faceplate shown above, the individual jacks will be identified (but not labeled on the faceplate) as follows:

Upper Left	123-1-1
Upper 2 <sup>nd</sup> from Left	123-1-2
Upper 3 <sup>rd</sup> from Left	123-1-3
Upper 4 <sup>th</sup> from Left	123-1-4
Upper Right	123-1-5
Lower Left	123-1-6
Lower 2 <sup>nd</sup> from Left	123-1-7
Lower 3 <sup>rd</sup> from Left	123-1-8

Lower 4 <sup>th</sup> from Left	123-1-9
Lower Right	123-1-10

4. The copper connections will be on jacks #2 and #7. Additional copper connections would go to jacks #1 and # 6 as needed.
5. The fiber connections will be on jacks #4 and #8.
6. Note that the Fiber connectors have a 30 Degree down slant on the faceplate.

The individual jack designations are not labeled on the faceplate due to space constraints. However, the jack designations are labeled in the Telecommunications Space on the appropriate patch panel or wiring block, as described below.

Each patch panel port shall be labeled with the individual jack designation connected to each port. For example, the patch panel port connected to jack 123-1-1 will be labeled 12311. The hyphens and are deleted due to space constraints.

In telecommunications spaces with multiple patch panels, each patch panel is sequentially numbered beginning with number "1."

**Wiring Blocks**

66 blocks will be covered with industry standard color-coded covers as follows:

Interbuilding Backbone Cable	Green
1 <sup>st</sup> Level Riser (Backbone) Cable	White
2 <sup>nd</sup> Level Riser (Backbone) Cable	Gray
Horizontal Cable	Blue

66 block covers will be labeled with the cable designation and pair count. For example:

Cable 01580/01780 – Pairs 1-50

110 blocks will be labeled with the same information as found on the 66 block covers.